

Atholl SCDC 4 Feb 2025 - Alison & Bill's Programme

1 GOOD HEARTED GLASGOW J32 · 3/4L

Peter Knapman: A Guide to Scottish Country Dancing (ex-Collins) · Crib: MiniCribs · Diagram: Keith Rose's Diagrams

- 1-8 1s turn RH & cast to 2nd place, turn partner LH 1.1/4 times
- 9-16 1s dance RH across (Lady with 2s at top & Man with 3s); 1s pass RSh & dance LH across with other couple
- 17-24 1s lead down the middle & back to 2nd place own side
- 25-32 2s+1s+3s circle 6H round & back

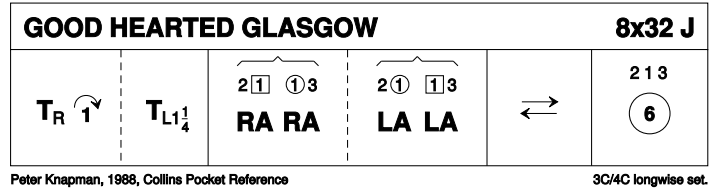

2 LOTHIAN LADS R32 · 3/4L

John Drewry: Summer Collection, Set 7 · Crib: MiniCribs · Diagram: Keith Rose's Diagrams

- 1-8 1s lead down & 3/4 turn RH to 1L facing down, 1M up, set, retain hold of RH & 1L turns under ptrns right arm, 1L followed by 1M dance up
- 9-16 1s dance RH across with 2L, 1s dance LH across with 3M to end facing 1st corners
- 17-24 1s dance 1/2 reel of 4 with 1st corners, pass RSh to face 2nd corners. 1s dance 1/2 reel with 2nd corners, end in 2nd place opp side facing down
- 25-32 3s+1s+2s dance 1/2 Grand Chain (pass 3 persons); retain RH with 3rd person & turn once round to end 2 1 3

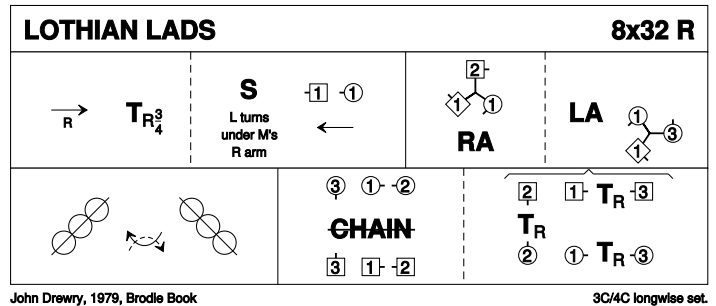

3 CAPE TOWN WEDDING S32 · 3/4L

Tom Kerr: RSCDS XXXIX 4 · Crib: MiniCribs · Diagram: Keith Rose's Diagrams

- 1-8 1s cross down (no hands) to 2nd place (2s step up), dance out & 1/2 turn 3s with nearer hand; 1s 1/2 turn RH & lead up to top ending in prom hold (2s+3s step down 7-8)
- 9-16 1s in prom hold dance reel of 3 with 2s (RSh to 2L to start) 1s end in middle at top facing down (Lady on Man's Left), 2s on sides & 3s step in & face up
- 17-24 1s+2s+3s set, all Petronella turn one place (1s+3s Petronella-in-Tandem); all set advancing (1 bar), join hands in circle & set (1 bar), pull back RSh & cast clockwise back to places
- 25-32 1s+2s dance the Knot. 2 1 3

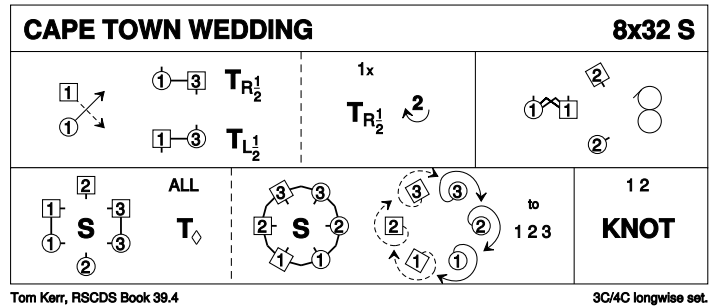

4 THE GALLOPING CAROUSEL J32 · 4/4L

John de Chastelain: RSCDS LIII 3 · Crib: MiniCribs · Diagram: Keith Rose's Diagrams

- 1-8 1s+2s also 3s+4s dance RH across, 1L also 4M followed by partner chase round clockwise to other end of dance
- 9-16 4s+2s also 3s+1s dance RH across, 1L also 4M followed by partner chase round clockwise back to places
- 17-24 1s+2s also 3s+4s set facing on sides & change places RH, middle couples set facing on sides & change places LH
- 25-32 Middle couples dance NHJ up/down between end couples, cast back to place & all turn RH. 2 4 1 3

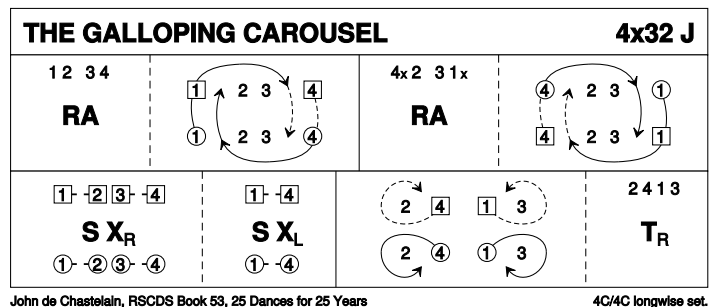

5 SUPERC-ALI-FRAGILISTIC R32 · 3/4L

Alison Austin · Crib: SCDDDB Contributed Cribs & Diagrams · Diagram: Keith Rose's Diagrams

- 1-4 1s set & cast 1 place
 5-8 1L dances 1/2 fig 8 round 3M while 1M dances 1/2 fig 8 round 2L
 9-16 1s turn RH 3/4, 1M+2s & 1L+3s set in lines across, all change places RH with opp person & chase 1/4 clockwise to sidelines
 17-24 1s pass Lsh to dance 1/2 Diag reel of 4 with 1st corners, passing RSh dance 1/2 reel with 2nd corner positions to 2nd place opp sides.
 25-28 1s turn LH 3/4 to 1L between 2L & 3L facing down, 1M between 2M and 3M facing up. All set in lines across.
 29-32 All cross LH with opp person & chase 1/4 anticlockwise to 2, 1, 3

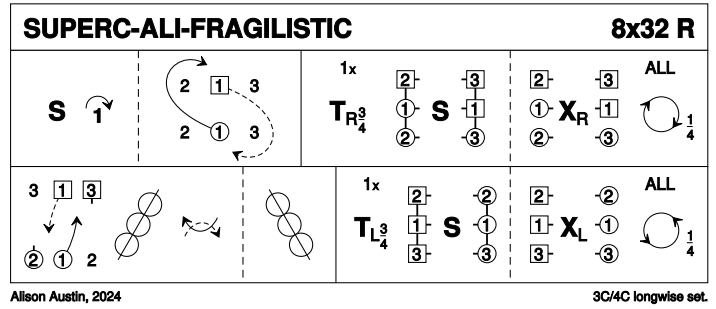

6 THE SINGING SANDS S32 · 3/3L

Barry Priddey: The Silver Rose Book of Scottish Country Dances · Crib: MiniCribs · Diagram: Keith Rose's Diagrams

- 1-8 1s & 2s dance the Tourbillon :
 1s & 2s turn partners 2H 1/2 way, 1M & 2L lead partners on 1 place clockwise to end 1s on Ladies side & 2s on Men's side, 1s set to 2s
 1s & 2s 1/2 turn partners 2H, 1L & 2M lead partners on 1 place to end 2s in 1st pl & 1s in 2nd pl & 2s+1s cross RH to own sides
 9-16 1s dance 1/2 Figs of 8 (Man round 2s & Lady round 3s), 1s dance 1/2 reels of 3 (Man with 3s & Lady with 2s)
 17-24 1s dance Diag R&L to end 3 1 2
 25-32 All set & 3s+1s dance RH across 1/2 way while 2s cross RH, all chase clockwise 1/2 way to end 2 3 1

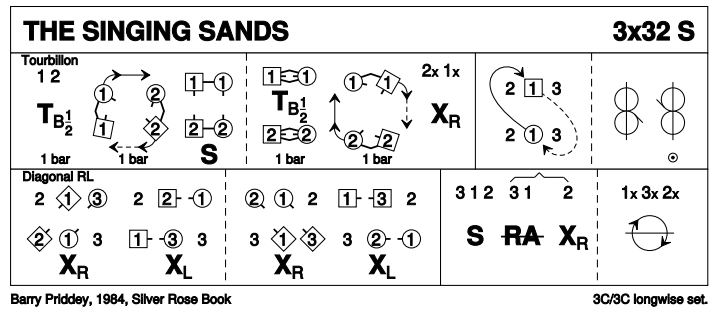

7 THE HAZEL TREE J32 · 3/4L

John Drewry: The Brodie Book · Crib: MiniCribs · Diagram: Keith Rose's Diagrams

- 1-8 1s+2s dance Espagnole:
 1-2 1s+2s cross (Ladies lead across RH passing between Men) with Ladies changing places RH
 3-4 1s+2s cross back (Men lead across RH between Ladies) with Men changing places RH
 5-8 2s turn RH as 1s turn LH to face 1st corners
 9-16 1s turn 1st corners RH, pass RSh, turn 3rd corner LH & pass LSh to face 2nd corner
 17-24 1s turn 2nd corners RH, pass RSh, turn 4th corner LH, 1s pass LSh to face down in middle (opposite sides) left hands joined
 25-32 1s lead down below 3s, cross, cast up to 2nd place own sides, 2s+1s+3s turn RH

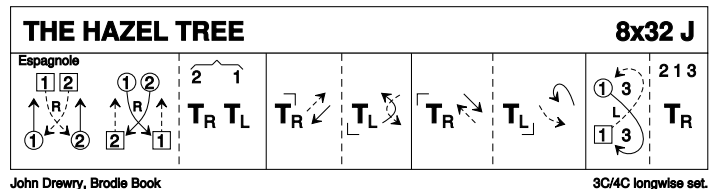

8 THE PLANTATION REEL R32 · 5/5L

Tony Moretti: Pinewoods Collection Vol 2 · Crib: MiniCribs · Diagram: Keith Rose's Diagrams

- 1-8 1s & 3s cross RH & cast down 1 place, lead down between the couple below & cast back to 2nd/4th place (opposite sides)
 9-16 2s+1s & 4s+3s dance 1/2 R&L & Petronella turn 2 places anticlockwise round square (end in same places as at bar 8)
 17-24 All dance RH across (1M with 2s, 1L+3M with 4s, 3L with 5s) & 1s & 3s change places with partners to dance LH across
 25-32 1s & 3s cross RH cast down 1 place & all turn RH

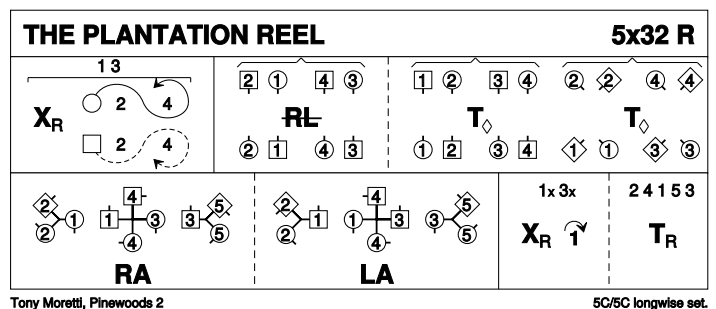

9 PROGRAMME ITEM – Interval

10 THE RAVEN'S DANCE J32 · 3/4L

Derek Haynes: Carnforth Collection of SC Dances 5 · Crib: MiniCribbs · Diagram: Keith Rose's Diagrams

- 1-8 1s+2s dance double Fig of 8 (1s cross down & 2s dance up to start - no cast)
- 9-16 1s cross down to dance reflection reels of 3 on opposite sides & end in centre at top facing down (Lady on Man's right), 2s facing out
- 17-24 1s (Lady leading) dance an Alternating Tandem RSh reel of 3 across with 2s (RSh to 2M) & end in centre facing down, 2s in 1st place own side
- 25-32 1s dance down between 3s, cast up to 2nd place (opp sides), lead up between 2s, cross & cast to 2nd place own sides

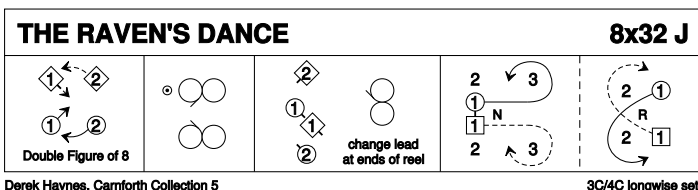

Derek Haynes, Carnforth Collection 5

3C/4C longwise set.

11 SHIFTIN' BOBBINS R32 · 3/4L

Roy Clowes: Thirty Popular Dances, Volume Two · Crib: MiniCribbs · Diagram: Keith Rose's Diagrams

- 1-8 1s cross RH to double triangle position with 2s+3s & set, 1s cast up to top & dance down until they are between 2s & 3s
- 9-16 1L dances RH across with 2M+3M while 1M dances LH across with 2L+3L, 1s followed by 2s+3s dance down centre
- 17-24 3s followed by 2s+1s dance up & 3s+2s cast down to places, 1L dances LH across with 2M+3M while 1M dances RH across with 2L+3L
- 25-32 1s dance up to top & cast down to 2nd place opposite side, 1s dance 1/2 Fig of 8 around 2s to end in 2nd place on own sides

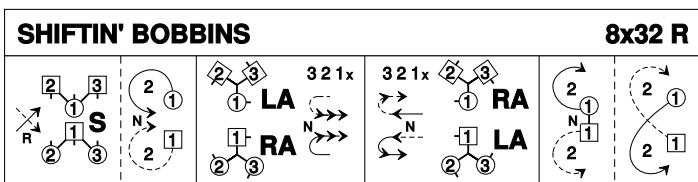

Roy Clowes, Ormskirk Book 6, RSCDS Thirty Popular Dances Vol 2

3C/4C longwise set.

12 THE FLOWER O' THE QUERN S32 · 4/4L

John Drewry: The Canadian Book of Scottish Country Dances · Crib: MiniCribbs · Diagram: Keith Rose's Diagrams

3s & 4s start on opp sides

- 1-8 1s+2s & 3s+4s circle 4H round to Left to end in middle, 1s facing 2s, 3s facing 4s. All set, 1s+4s turn inwards towards partner & cast in 1 pl down/up (2s dance up, 3s dance down one pl) & 1M+4L also 1L+4M change places LH on sides 2 (4) 1 (3)
- 9-12 1s+4s lead out of ends, cross & cast. 1s+4s change places LH on sides.
- 13-16 1s & 4s repeat 9-12, leading out other end, cross & cast & 1s+4s change places LH on side. 1s face down, 4s face up
- 17-24 All dance reels of 4 on sides & end facing same person as at start of reel. 2 (4) 1 (3)
- 25-32 2s+4s also 1s+3s set facing on sides, 1s & 4s turn end couples (dancing between ends) & dance 1/2 Figs of 8 round end couples to end 2 4 (1) (3)

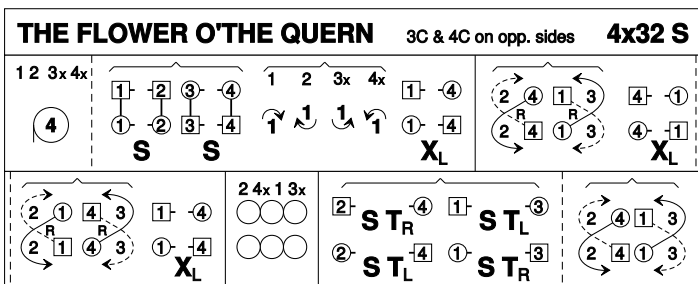

John Drewry, 1977, Canadian Book

4C/4C longwise set.

13 QUARRIES' JIG J32 · 3/4L

Kent W Smith: RSCDS XXXVI 3 · Crib: MiniCribbs · Diagram: Keith Rose's Diagrams

- 1-8 1s set, cast 1 place & dance round 1st corners passing corners LSh
- 9-16 1s dance reels of 3 across (1st Man with 2s & 1st Lady with 3s), 1s turn LH to face 1st corners
- 17-18 Centre dancers change with 1st corners RH while 2nd corners set
- 19-20 1st corners (in centre) change places LH while new 1st & 2nd corners dance clockwise round to next corner place
- 21-24 Repeat the Fig in bars 17-20 from new places
- 25-32 Repeat 17-20 from new places, 1s end by turning LH to 2nd place on opposite sides, 2s+1s+3s set on sides & 1s cross back RH

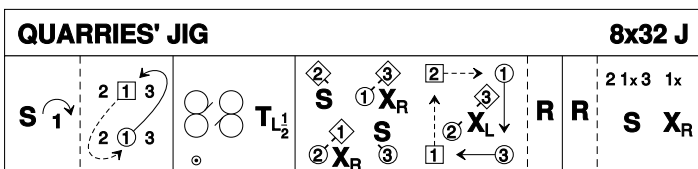

Kent W Smith, RSCDS Book 36.3

3C/4C longwise set.

14 THE LOCHALSH REEL R40 · 3/4L

Pat Burnett: RSCDS LIII 1 · Crib: MiniCribbs · Diagram: Keith Rose's Diagrams

- 1-8 1s turn RH, cast 1 place, cross LH, cast 1 place to meet partner in prom hold facing 3M (Lady on Man's left)
- 9-16 1s dance LSh reel of 3 across with 3s
- 17-24 1s separate to dance reels of 3 on opposite sides
- 25-32 1s dance NHJ up to top, turn 2s with other hand, cross down between 3s & cast up to 2nd place own sides
- 33-40 1s dance RH across (Lady with 2s & Man with 3s), pass RSh to dance LH across with other couple

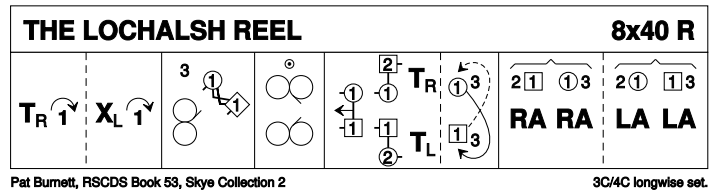

15 BROADWAY S32 · 3/3L

Chris Ronald: The Big Apple Collection · Crib: MiniCribbs · Diagram: Keith Rose's Diagrams

- 1-8 1s dance down (2 bars) & turn 2H (2 bars), 1s dance up & cast to 2nd place
- 9-16 2s+1s+3s Set+Link for 3, 1s dance 1/2 Diag R&L starting Diagonally left
- 17-24 All Set+Link for 3, 1s dance 1/2 Diag R&L starting Diagonally left. (3)(1)(2)
- 25-32 All set & 1/2 turn RH, face partner and pull back RSh, dance out to places & set. 3 1 2

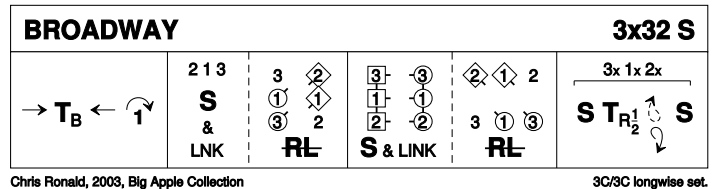

16 BEST SET IN THE HALL J32 · 3/4L

Helen Greenwood: RSCDS XLVI 7 · Crib: MiniCribbs · Diagram: Keith Rose's Diagrams

- 1-8 1s set & 1L followed by partner casts below 3s. 1L crosses & casts up to face her 1st corner **while** 1M dances up the middle to face 1st corner
- 9-12 1s set to 1st corners & dance RSh round each other into 3rd corner (pstrn) **while** 1st corners dance in & turn right about to face their original position
- 13-16 1s+1st crnr person set & 1st crnr persons dance RSh round each other into diag opp crnrs **while** 1s dance in & pivot to right to face 2nd crnrs
- 17-24 1s repeat bars 9-16 with 2nd corners & end passing RSh to 2nd place opposite sides. (3)(1)(2)
- 25-32 3s+1s+2s chase clockwise 1/2 way & turn partners RH

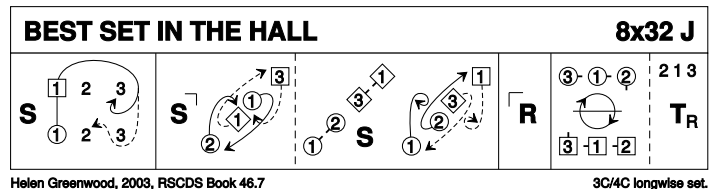

17 THE DEIL AMANG THE TAILORS R32 · 3/4L

RSCDS XIV 7 · Crib: MiniCribbs · Diagram: Keith Rose's Diagrams

- 1-8 1s+2s set & dance RH across 1/2 way, set & dance LH across 1/2 way back to place
- 9-16 1s lead down the middle & back to top
- 17-24 1s+2s dance Allemande
- 25-32 2s+1s+3s circle 6H round & back

