

Atholl SCDC 29 Oct 2024 - Sarah's Programme

1 THE LUCKENBOOTH BROOCH J32 · 3/4L

John Bowie Dickson: RSCDS LIII 6 · Crib: MiniCribs · Diagram: Keith Rose's Diagrams

- 1-8 1s in prom hold (Lady on Man's left) dance reel of 3 with 2s (RSh to 2M) & end facing 3M
- 9-16 1s dance reel with 3s (RSh to 3M) ending with 1s dancing into centre facing Men's side
- 17-24 1M casts up & 1L dn into centre & dance out Ladies' side, 1M cast up & 1L dn to end 1M b'tw'n 2s facing dn & 1L+3s face up as 2s+3s dance R&L
- 25-32 2s+1s+3s set twice, 1s turn RH 1.3/4 times to 2nd places

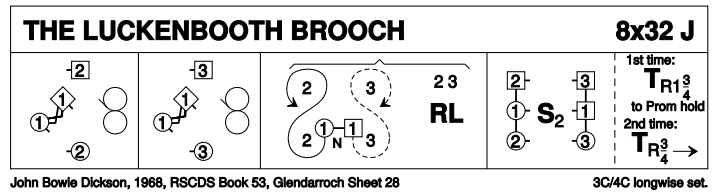

2 THE MUSIC MAKARS R32 · 3/4L

Roy Goldring: RSCDS XXXIII 1 · Crib: MiniCribs · Diagram: Keith Rose's Diagrams

- 1-8 1s turn RH, cast 1 place & turn partner LH to Bal-in-Line position with 1st corners
- 9-16 1s Bal-in-Line with 1st corners then face 1st corners & set, 1s turn to right again & Bal-in-Line with corners then turn ptrn RH to face 2nd crnrs
- 17-24 1s Bal-in-Line with 2nd corners then face 2nd corners & set, 1s turn to left again & Bal-in-Line with corners then turn ptrn LH to end 1L facing 2s, 1M facing 3s
- 25-32 1s dance RH across (1L with 2s & 1M with 3s), 1s change places passing RSh & dance LH across with other couple. 2 1 3

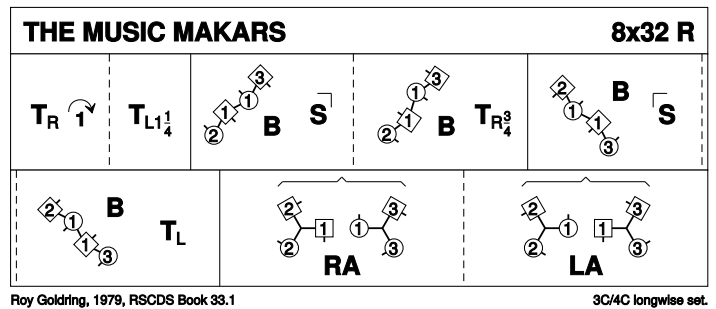

3 CHERRYBANK GARDENS S32 · 3/3L

John Drewry: Thirty Popular Dances, Volume Two · Crib: MiniCribs · Diagram: Keith Rose's Diagrams

- 1-8 1s+2s set & Petronella-in-tandem twice to end with 2s+1s on opposite sides having changed places. (2) (1) 3
- 9-16 2s+1s set, 2s cross RH while 1s 3/4 turn LH; 1L+2s (at top) & 1M+3s dance RH across
- 17-24 1s+3s Set+Link & circle 4H round to left. 3s face down, 1s face up ready for ...
- 25-32 2s+3s+1s dance Grand Chain (2s cross, 3s+1s change places RH on sides)

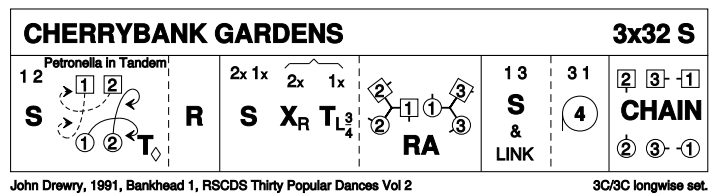

4 THE PEAT FIRE FLAME R40 · 3/4L

John Drewry: Bon Accord Book of Scottish Country Dances · Crib: MiniCribs · Diagram: Keith Rose's Diagrams

- 1-8 1s cast 1 place & dance 1/2 Fig of 8 round 2s & turn 3/4 LH to face 1st corners
- 9-16 1s turn 1st corner RH, pass partner RSh & turn 2nd corner LH pass partner LSh to face 1st corners
- 17-24 1s dance 1/2 diagonal reel of 4 with 1st corners & 1/2 diagonal reel with 2nd corners to end in centre BtoB facing 3rd corners (1st corner persons)
- 25-32 1s set to 3rd corners & dance round one another clockwise to 4th corners, set & dance clockwise to face out on opposite sides
- 33-40 1s dance out & cast round 1st corner into centre while 2s & 3s dance 1/2 R&L, 2s+1s+3s turn RH

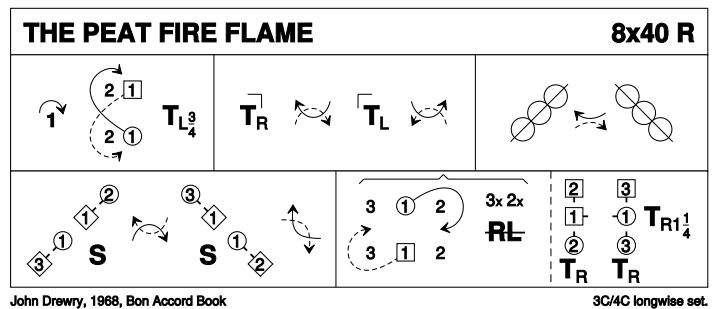

5 MACPHERSON'S JIG J32 · 3T

Roger Bestwick: Rannoch Sheets · Crib: MiniCribs · Diagram: Keith Rose's Diagrams

- 1-8 1s cross out through sides cast down & dance up centre, 1L dances RH across with 2s & 1M dances LH with 3s & all end prom hold
- 9-16 All dance full reel of 3 across set (1s pass 2s RSh to start)
- 17-24 1s dance out through side couples (1M through 3s, 1L through 2s) & cast back to places, all turn partners LH (1s turn 1.1/2 times)
- 25-32 1s+3s dance 1/2 R&L, 3s+2s dance 1/2 R&L all ending 1 place round anticlockwise with 2s at top

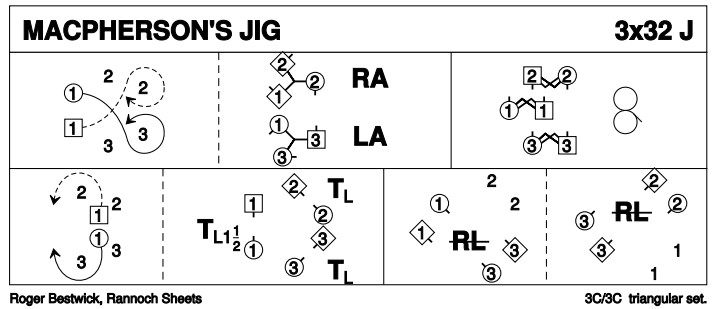

6 GANG THE SAME GATE S32 · 3/4L

Milton Levy: RSCDS XXXVI 4 · Crib: MiniCribs · Diagram: Keith Rose's Diagrams

- 1-8 1s cross RH & cast down to 3rd place, cross RH & cast up to 2nd place on own sides
- 9-16 1s set adv to ptr & turn 1st crnr 2H to face 2nd crnr, 1s dance 1/2 diag reel of 4 ending M b'tw'n top cpl facing down & L b'tw'n bottom cpl facing up
- 17-24 1s set adv to partner & turn 4th corner (pstrn) 2H to face own 1st corner (pstrn), 1s dance 1/2 diag reel with 1st corners ending in 2nd place opp sides
- 25-32 3s+1s+2s Set+Link for 3 twice

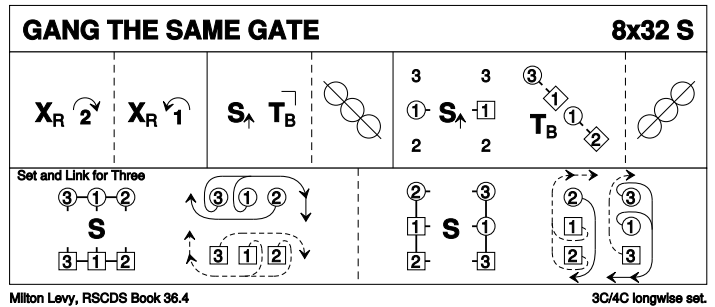

7 CLUTHA R48 · 4S

RSCDS XXXI 2 · Crib: MiniCribs · Diagram: Keith Rose's Diagrams

- 1-8 1L+3M turn RH, dance round partner RSh to turn each other again RH ending in middle holding RH & partners LH
 - 9-16 1s+3s Bal-in-Line, 1L+3M turn partners LH into the middle & Bal-in-Line again, turn partner LH to original pstrns
 - 17-24 1s+3s dance R&L
 - 25-32 1s+3s dance Ladies' Chain
 - 33-40 All turn corners RH retaining hold & hold partners LH to form a circle (men facing out), all set & turn partner LH (4 bars) into prom hold
 - 41-48 All dance round anticlockwise in prom hold to original pstrns
- Repeat with 2L+4M, 3L+1M, 4L+2M

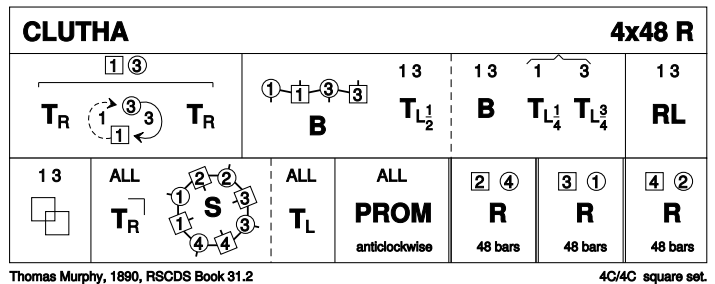

8 QUARRIES' JIG J32 · 3/4L

Kent W Smith: RSCDS XXXVI 3 · Crib: MiniCribs · Diagram: Keith Rose's Diagrams

- 1-8 1s set, cast 1 place & dance round 1st corners passing corners LSh
- 9-16 1s dance reels of 3 across (1st Man with 2s & 1st Lady with 3s), 1s turn LH to face 1st corners
- 17-18 Centre dancers change with 1st corners RH while 2nd corners set
- 19-20 1st corners (in centre) change places LH while new 1st & 2nd corners dance clockwise round to next corner place
- 21-24 Repeat the Fig in bars 17-20 from new places
- 25-32 Repeat 17-20 from new places, 1s end by turning LH to 2nd place on opposite sides, 2s+1s+3s set on sides & 1s cross back RH

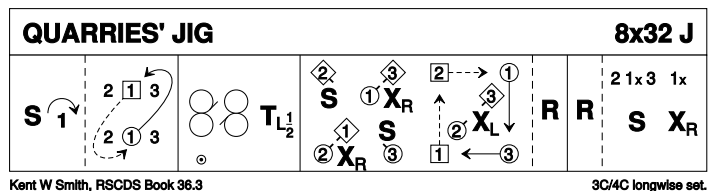

9 PELORUS JACK J32 · 3/4L

Barry Skelton: RSCDS XLI 1 · Crib: MiniCribs · Diagram: Keith Rose's Diagrams

- 1-8 1s cross RH & cast 1 place (2s step up 3-4), 1s dance RH across with 3s. 1s end with Man facing his 1st corner with his partner behind him
- 9-16 1s dance Alternating Tandem 1/2 reel of 3 with 1st corners to face Man's 2nd corner, 1s dance Alternating Tandem 1/2 reel of 3 with 2nd corners
- 17-24 1s dance Alternating Tandem 1/2 reels of 3 with Ladies' 1st corner (pstn), 1s dance Alternating Tandem 1/2 reel with Ladies' 2nd corner (pstn)
- 25-32 1M followed by partner dance into LH across with 2s, 1s retain LH & 1/2 turn to own sides & 2s+1s+3s set

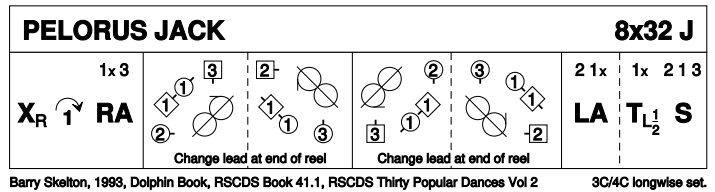

10 THE CHAIRMAN R32 · 3/4L

John Bowie Dickson: Dunedin Dances Book 4 · Crib: MiniCribs · Diagram: Keith Rose's Diagrams

- 1-8 1s set, cross RH, cast 1 place & turn RH to 2nd place on opposite side
- 9-16 1s dance Interlocking reels of 3 across giving RSh to 1st corner **while** 2s+3s dance reels of 3 on sides, 1s end 2nd place opposite sides
- 17-24 1s dance Interlocking reels of 3 across giving LSh to 2nd corner **while** 2s+3s dance reels of 3 on sides, 1s end 2nd place opposite sides
- 25-32 2s+1s+3s set, 1s 3/4 turn RH & set in lines across, 1s turn RH to 2nd place own sides

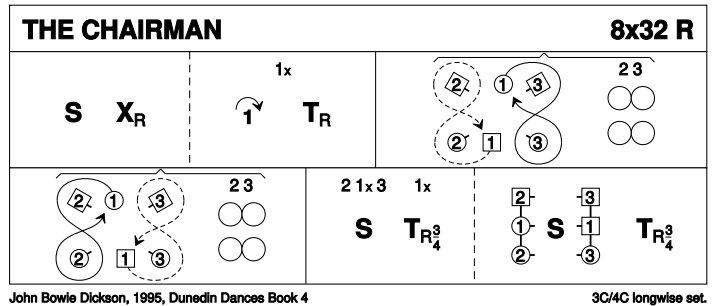

11 ARGYLL STRATHSPEY S32 · 3/4L

Roy Goldring: RSCDS XXXV 3 · Crib: MiniCribs · Diagram: Keith Rose's Diagrams

- 1-8 1s+2s+3s 1/2 turn RH, twirl & dance out to opposite sides & repeat back to place
- 9-16 1s+2s+3s circle 6H round & back (1s end in centre facing down & 3s in centre facing up)
- 17-24 1s+3s dance R&L (up & down) & end back on own sides
- 25-32 1s+2s dance the Tournee:

1s+2s dance into prom hold (Men with prtnr on right, 1s face M's side & 2s L's side), couples 1/2 wheel anticl'wise & Men turn Ladies into middle, both couples turn 1.1/2 times (2s RH, 1s LH) & dance out to places

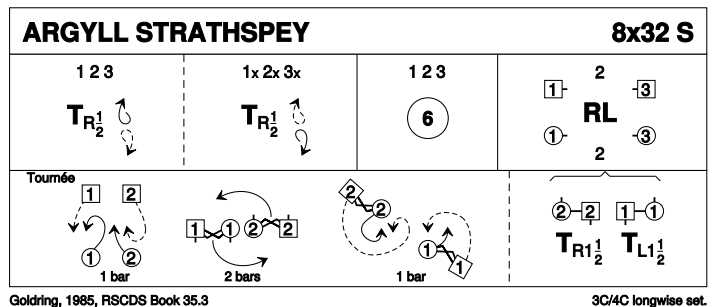

12 THE CHEQUERED COURT J32 · 3/4L

Duncan Brown: RSCDS XLII 3 · Crib: MiniCribs · Diagram: Keith Rose's Diagrams

- 1-8 1s cross RH, cast 1 place (2s step up), 1s dance 1/2 Figs of 8 (Man round 2s & Lady round 3s) & end facing 1st corners
- 9-16 1s dance Pass+Turn with 1st corners & 1s twirl round in centre to face 4th cnrs, 1s dance Pass+Turn with 4th cnrs & twirl round to BtoB facing own sides
- 17-24 1s dance 6 bars of Double Triangles & end with Petronella turn to 1L between 2s facing 2L & 1M between 3s facing 3M
- 25-32 1s dance reel of 3 across giving RSh to 4th corners (6 bars) & 1s cross RH to own sides

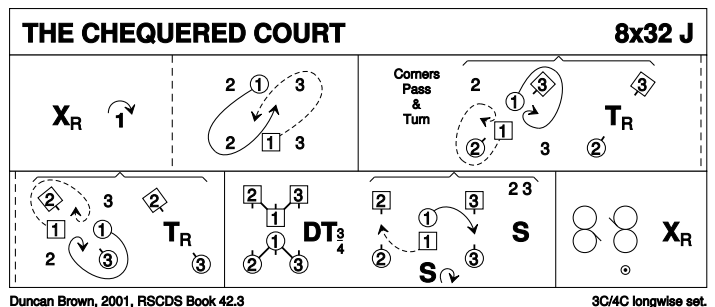

13 STAIRCASE IN STYRIA R40 · 5/5L

Margaret Gray: CD booklet of The Sunday Class Dance Book 2 · Crib: MiniCribs · Diagram: Keith Rose's Diagrams

- 1-8 1s+2M also 3s+4M dance RH across, 1s+2L also 3s+4L dance LH across
 - 9-16 1s+4M also 3s+5M dance RH across, 1s+4L also 3s+5L dance LH across & 1L also 3L end facing out Ladies side with partners behind them
 - 17-24 1s & 3s dance out Ladies' side & cast up 1 place, cross to Mens side & cast up to original place Ladies looping round by the right
 - 25-32 1s cross & cast 1 place, 1s followed by 3s dance up & cast (1s to 3rd place, 3s to 2nd place)
 - 33-40 1s cross & cast 1 place, 1s followed by 5s dance up & cast (1s to 5th place, 5s to 4th place). 2 3 4 5 1
- NB - No stepping up or down until bar 27

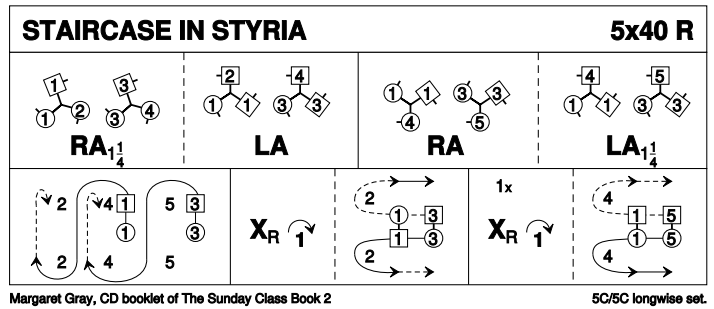

14 CITY OF BELFAST S32 · 3/3L

Lucy Mulholland: RSCDS XLVIII 6 · Crib: MiniCribs · Diagram: Keith Rose's Diagrams

- 1-8 1s dance 1/2 Fig of 8 round 2s, 1L+2M turn RH 1.1/4 times while 1M+2L turn LH 1.1/4 times & 1s end BtoB facing opp sides
 - 9-16 1s+2s dance reel of 4 across in 2nd place. 2s end in 1st places while 1s pass LSh to face 1st corners
 - 17-24 1s set to 1st corner & 2nd corner ending (turning to right) between corners, all set & 1s cross RH
 - 25-32 1s+3s dance Espagnole:
- 25-26 1s+3s cross (Ladies lead across RH passing between Men) with Ladies changing places RH
- 27-28 1s+3s cross back (Men lead across RH between Ladies) with Men changing places RH
- 29-32 3s turn RH as 1s turn LH to end 2 3 1

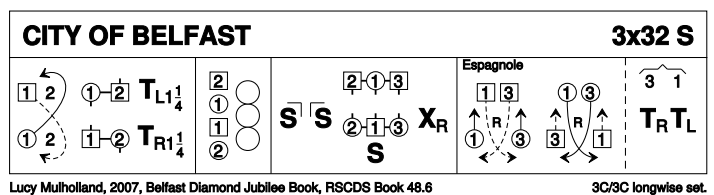

15 THE KELLOHOLM JIG J32 · 3/4L

Peter Hyssett: The Leaflet Dances with Music · Crib: MiniCribs · Diagram: Keith Rose's Diagrams

- 1-8 1s set & cast 1 place, set on side lines to 1st corners & change places with them RH
- 9-16 1L+3L also 2M+1M set to each other on sides & change places LH, 1s turn RH 1.1/2 times to 2nd place on own sides
- 17-24 1s set on side lines to 2nd corners & change places with them RH, 1M+3M also 2L+1L set to each other on sides & change places LH
- 25-32 3s+1s+2s Adv+Ret, circle 6H round 1/2 way to left

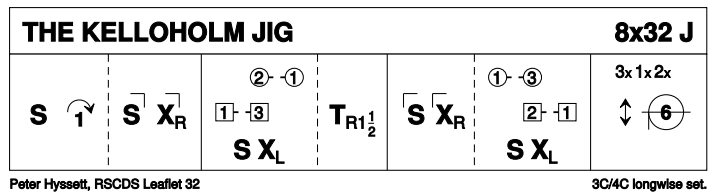

16 MAIRI'S WEDDING R40 · 3/4L

James B Cosh: Twenty Two SCD · Crib: MiniCribs · Diagram: Keith Rose's Diagrams

- 1-8 1s turn RH & cast to 2nd place (2s step up); 1s turn LH to face 1st corners
- 9-16 1s dance 1/2 diagonal reel of 4 with 1st corners, 1s dance 1/2 diagonal reel with 2nd corners
- 17-24 1s dance 1/2 diagonal reel with 3rd corner (pstns), 1/2 diagonal reel with 4th corner (pstns)
- 25-32 1s dance reel of 3 across (Lady with 2s, Man with 3s - LSh to 1st corner)
- 33-40 2s+1s+3s circle 6H round & back

