

Atholl SCDC - 24 March 26 - Alison N's Programme

1 MAXWELL'S RANT R32 · 3/4L

David Rutherford: RSCDS XVIII 10 · Crib: MiniCribbs · Diagram: Keith Rose's Diagrams

- 1-8 1s cross down to dance reflection reels of 3 on opposite sides
- 9-16 1s cross down to dance reflection reels of 3 on own sides
- 17-24 1s cross RH, cast to 2nd place & dance 1/2 Fig of 8 round 2s
- 25-32 1s dance down between the 3s, cast up to 2nd place & 2s+1s+3s turn partners RH

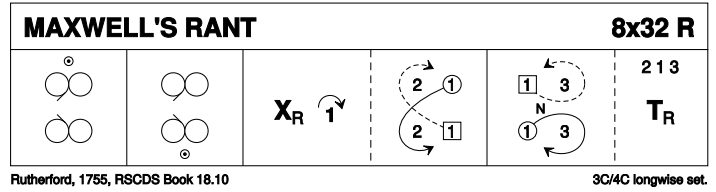

2 GEORGIE'S JIG J32 · 4/4L

Lewis N Derrick: The Leaflet Dances with Music · Crib: MiniCribbs · Diagram: Keith Rose's Diagrams

- 1-8 1L+2M also 3L+4M set facing diagonally, Ladies cast 1 pl as Men cast up & dance into centre (1M & 2L also 3M & 4L step down/up 1/2 pl), top 4 dancers also bottom 4 dance RH across
- 9-16 2M+1L+4M+3L dance 1/2 reel of 4 up/down centre, top 4 dancers also bottom 4 dance RH across 1.1/4 times to bring other dancers into centre
- 17-24 1M+2L+3M+4L dance 1/2 reel of 4 in centre, top 4 dancers also bottom 4 dancers dance RH across to end with 4s+3s+2s in centre for Allemande
- 25-32 4s+3s+2s dance Allemande

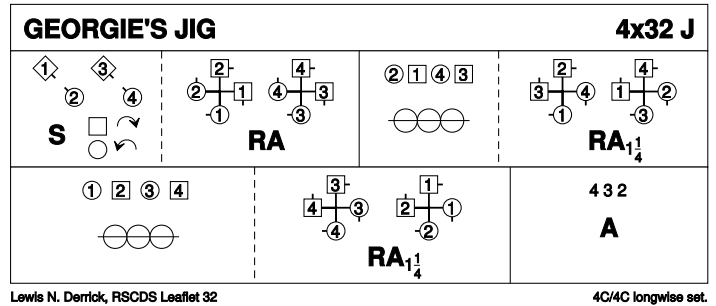

3 THE ROSE OF THE NORTH S32 · 3/4L

Roy Goldring: Silver Jubilee 25 - Leeds Branch · Crib: MiniCribbs · Diagram: Keith Rose's Diagrams

- 1-4 1s lead down below 3s, cross & cast up to 2nd place on opposite side
- 5-16 2s+1s+3s dance 3 couple R&L, 1s end facing 1st corners
- 17-24 1s set to & turn 1st corner 2H, set to & turn 2nd corner 2H. 1s finish BtoB in centre, 1M facing up, 1L facing down
- 25-32 1M+2s & 1L+3s circle 3H round to left & on bar 4 1s pull back RSh to face each other & set; 1s Petronella turn to 2nd place own side. 2 1 3

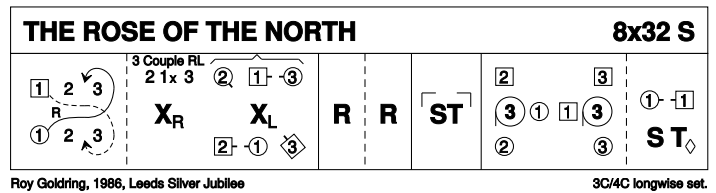

4 DON'T PANIC R40 · 3/4L

Robert Atkinson: Dances of Valour · Crib: MiniCribbs · Diagram: Keith Rose's Diagrams

- 1-8 1s cross RH, cast 2 places (2s up), cross LH below 3s & cast up to 2nd place. 2 1 3
- 9-16 1s dance 1/2 LSh Reels of 3 across (1L up, 1M down); 1s dance 1/2 RSh Reels of 3 on opp sides (1M up, 1L down), 1s finish in promenade hold facing down between 2s in 3rd place
- 17-24 1s dance RSh round 3M's place & up middle to 1st place as 2s 1/2 turn RH into promenade hold & follow 1s; 1s, followed by 2s, dance RSh round 3M (in 1L pos) & down middle. 3s step in to face down in promenade hold on bar 24.
- 25-32 All promenade down (3 bars), drop LH and cross to own sides (Lady under Man's arm); All lead up to own sides 3 2 1
- 33-40 3s+2s (top 2 couples) 1/2 turn partners RH, dance 1/2 RH across; 3s+1s (bottom 2 couples) 1/2 turn partners RH and dance 1/2 RH across. 2 1 3

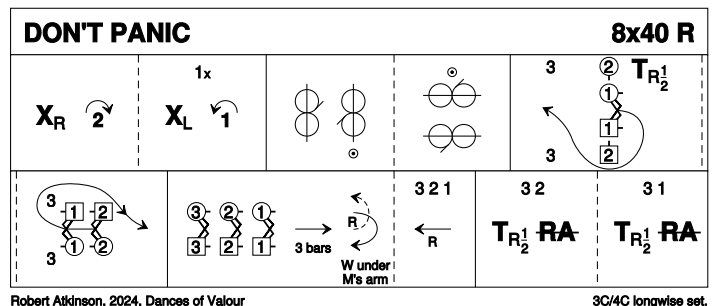

5 THE HAAR ON THE HILL J32 · 3/4L

Rona McLeod: West Lothian Branch Book WL50 · Crib: MiniCribs · Diagram: Keith Rose's Diagrams

- 1-8 1s cross down, dance out round 3s, meet & dance up middle to end BtoB facing out on opp sides, join hands with corners & set
- 9-16 1s change places with 1st corners RH, 1st corners change places with 2nd corners LH, 2nd corners change places with 1s RH & 1s face out again & set with corners
- 17-24 1s dance RSh round 1st corner (position) to meet in centre & 2s+1s+3s turn partners RH, remaining in centre facing up ready for ...
- 25-32 2s+1s+3s dance Allemande

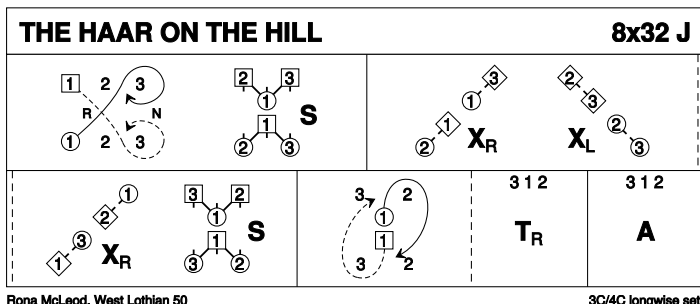

6 THE FLOWER O' THE QUERN S32 · 4/4L

John Drewry: The Canadian Book of Scottish Country Dances · Crib: MiniCribs · Diagram: Keith Rose's Diagrams

3s & 4s start on opp sides

- 1-8 1s+2s & 3s+4s circle 4H round to Left to end in middle, 1s facing 2s, 3s facing 4s. All set, 1s+4s turn inwards towards partner & cast in 1 pl down/up (2s dance up, 3s dance down one pl) & 1M+4L also 1L+4M change places LH on sides 2 (4) 1 (3)
- 9-12 1s+4s lead out of ends, cross & cast. 1s+4s change places LH on sides.
- 13-16 1s & 4s repeat 9-12, leading out other end, cross & cast & 1s+4s change places LH on side. 1s face down, 4s face up
- 17-24 All dance reels of 4 on sides & end facing same person as at start of reel. 2 (4) 1 (3)
- 25-32 2s+4s also 1s+3s set facing on sides, 1s & 4s turn end couples (dancing between ends) & dance 1/2 Figs of 8 round end couples to end 2 4 (1) (3)

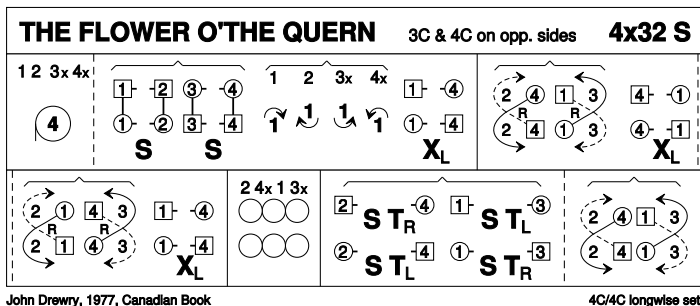

7 STARLIGHT R32 · 3/4L

Ed Abdill: RSCDS XLIV 1 · Crib: MiniCribs · Diagram: Keith Rose's Diagrams

- 1-8 1s cross RH, cast 1 place, PdB in turn right about to face opposite sides & set as double triangles
- 9-16 1s dance out, cast round 1st corners into centre **while** 2s+3s Adv+Ret diagonally, 1s PdB towards each other & turn right about to face up/down & set as double triangles
- 17-24 1s dance up/down, cast to right to 2nd place own sides **while** 2s+3s Adv+Ret, 1s dance RH across (1L with 2s & 1M +3s) end facing 1st crnrs
- 25-32 1s dance 'Hello-Goodbye' setting ending with petronella turn to 2nd places

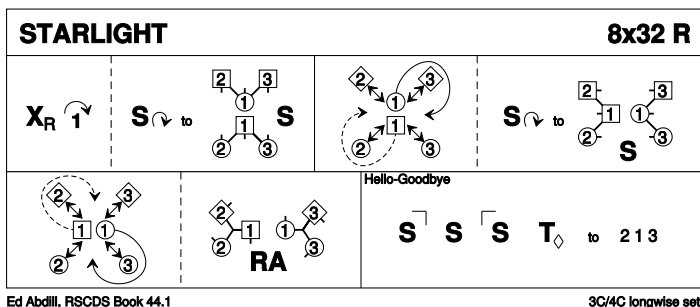

8 FATHER CONNELLY'S JIG J64 · 4/4L

John Drewry: *The Donside Book* · Crib: *MiniCribs* · Diagram: Keith Rose's Diagrams

- 1-8 1s+2s Set & Rotate:
Set, rotate singly & dance on 1 place clockwise, change places RH on sides & dance on 1 place to own sides. Order 2 1 3 4
- 9-16 1s dance 1/2 diag R&L with 1st corners **while** 2nd corners set & change places diagonally RH, 1s dance 1/2 RSh reels of 3 on opposite sides (1M up, 1L down). (2)(1)(3) 4
- 17-24 1s dance 1/2 diag R&L with 3rd corner (pstn) **while** 2nd corners (pstn) set & change places diagonally, 1s dance 1/2 RSh reels of 3 on own sides (1M down, 1L up). 2 1 3 4
- 25-32 1s dance reels of 3 across Lady with 2s & Man with 3s (LSh to 1st corner)
- 33-40 1s cross down between 3s, 1L casts up round 3M & 1M casts down round 4L, 1s change places LH in centre & cast to 3rd place own sides
- 41-56 3s+1s+4s (bottom 3 couples) repeat bars 9-24. Order 2 3 1 4
- 57-64 All (or bottom 3 couples only) circle 8(6)H round & back. 1s step down to end 2 3 4 1

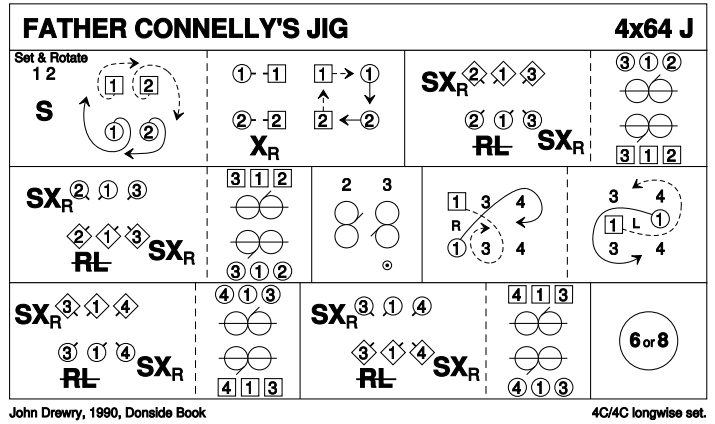

9 LIQUID ASSETS J32 · 3/4L

John Drewry: *New Dances by John Drewry 2003* · Crib: *MiniCribs* · Diagram: Keith Rose's Diagrams

- 1-8 1s cross down to dance reflection reels of 3 on opposite sides 1s ending at top on opposite sides facing in & 2s face out
- 9-16 1s turn 2s 1.1/2 times with nearer hands, 1s turn 3s 1.1/2 times with other hand
- 17-24 1s cross up to dance reels of 3 on own side At end 3s face out
- 25-32 1s turn 3s 1.1/2 times with nearer hands, 1s dance up to top & cast to 2nd places

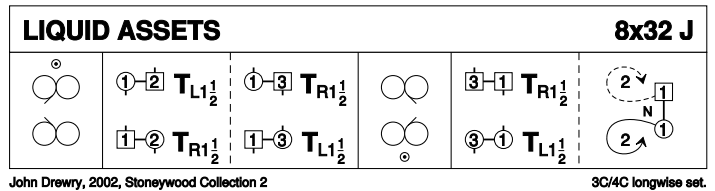

10 ON THE QUARTER-DECK R32 · 2/4L

Iain Boyd: *The Harbour City* · Crib: *MiniCribs* · Diagram: Keith Rose's Diagrams

- 1-8 1s set & cross over RH, set & 3/4 turn RH
- 9-16 1s dance RH across with 2M & LH across with 2L
- 17-24 1L followed by 1M dance down for 2 & 1M followed by 1L dance up for 2, both cast on Ladies side & 1M crosses to 2nd place own side
- 25-32 2s+1s R&L

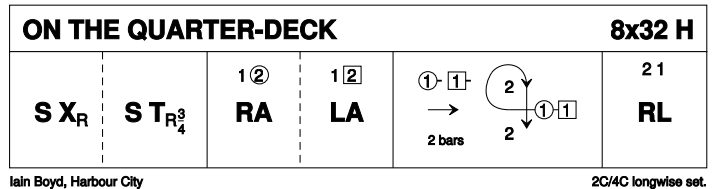

11 YSOBEL S32 · 3/4L

John Drewry: *RSCDS LIII 11* · Crib: *MiniCribs* · Diagram: Keith Rose's Diagrams

- 1-8 1s+2s petronella turn & set, 3/4 turn RH into 1/2 RH across
- 9-16 1s cross down RH through 3rd place to dance reel of 3 with 2s+3s on opp sides (2s+3s start passing RSh on Ladies' side & LSh on Men's side). 1s end facing 2nd crns
- 17-24 1s dance 1/2 reel of 4 with 2nd corners, pass LSh round each other to 1/2 reel with 1st corner & passing LSh 1M faces 3s (at top) 1L faces 2s
- 25-32 3s+1s+2s set & 3s+1M also 1L+2s circle 3H round to left, 1M leads 3s down Ladies side **while** 1L leads 2s up Men's side & circle 6H round 1/2 way. 2 1 3

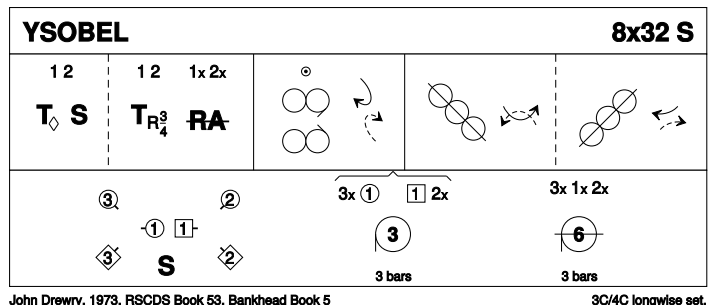

12 BLEATHERING BETH J32 · 3/4L

Garry Robertson: 90 - Twelve anniversary dances celebrating ninety years of RSCDS Edinburgh Branch 1 · Crib: MiniCribbs · Diagram: Keith Rose's Diagrams

- 1-8 1L followed by 1M casts 1 place, dances across to 2nd place opp. sides (2s step up 3-4). 1L+2M also 1M+2L turn RH
- 9-16 1L followed by 1M casts down 1 place, dances across to 3rd place own sides (3s step up 11-12). 1M+3M also 1L+3L turn LH
- 17-24 1s set, dance up middle, finish back to back facing own sides 2nd place (3s step down 19-20) 2s+1s+3s dance 4 bars Double Triangles
- 25-32 1L casts up round 2M, thru 2s as 1M casts down round 3L, thru 3s to 2nd place own sides. 2s+1s+3s turn RH (1L remains facing out to repeat)

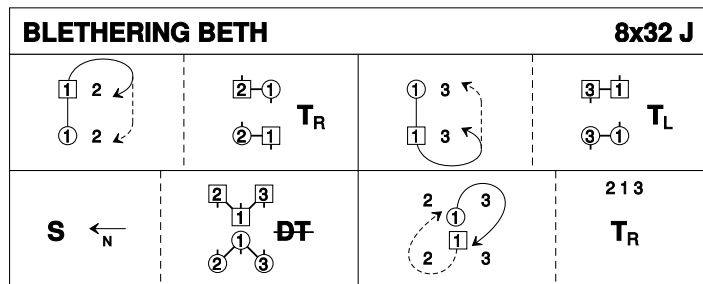

Garry Robertson, 2012, Edinburgh 90th Anniversary

3C/4C longwise set.

13 LOTHIAN LADS R32 · 3/4L

John Drewry: Summer Collection, Set 7 · Crib: MiniCribbs · Diagram: Keith Rose's Diagrams

- 1-8 1s lead down & 3/4 turn RH to 1L facing down, 1M up, set, retain hold of RH & 1L turns under ptrns right arm, 1L followed by 1M dance up
- 9-16 1s dance RH across with 2L, 1s dance LH across with 3M to end facing 1st corners
- 17-24 1s dance 1/2 reel of 4 with 1st corners, pass RSh to face 2nd corners. 1s dance 1/2 reel with 2nd corners, end in 2nd place opp side facing down
- 25-32 3s+1s+2s dance 1/2 Grand Chain (pass 3 persons); retain RH with 3rd person & turn once round to end 2 1 3

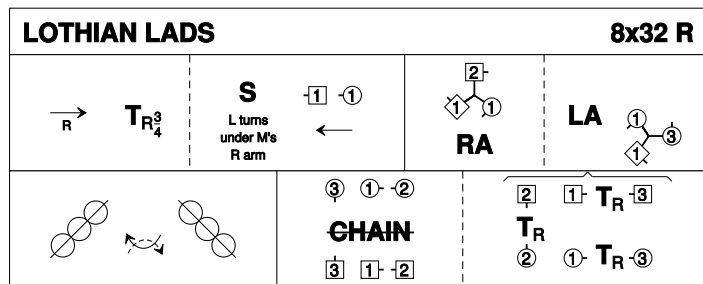

John Drewry, 1979, Brodie Book

3C/4C longwise set.

14 CITY OF BELFAST S32 · 3/3L

Lucy Mulholland: RSCDS XLVIII 6 · Crib: MiniCribbs · Diagram: Keith Rose's Diagrams

- 1-8 1s dance 1/2 Fig of 8 round 2s, 1L+2M turn RH 1.1/4 times **while** 1M+2L turn LH 1.1/4 times & 1s end BtoB facing opp sides
- 9-16 1s+2s dance reel of 4 across in 2nd place. 2s end in 1st places **while** 1s pass LSh to face 1st corners
- 17-24 1s set to 1st corner & 2nd corner ending (turning to right) between corners, all set & 1s cross RH
- 25-32 1s+3s dance Espagnole:
 - 25-26 1s+3s cross (Ladies lead across RH passing between Men) with Ladies changing places RH
 - 27-28 1s+3s cross back (Men lead across RH between Ladies) with Men changing places RH
 - 29-32 3s turn RH as 1s turn LH to end 2 3 1

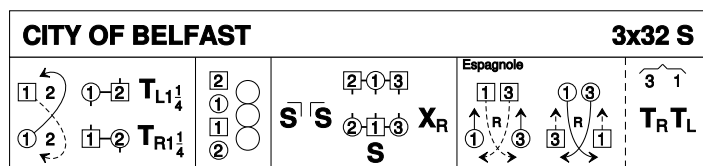

Lucy Mulholland, 2007, Belfast Diamond Jubilee Book, RSCDS Book 48.6

3C/3C longwise set.

15 MRS STEWART'S JIG J32 · 3/4L

Frans Ligtmans: RSCDS XXXV 1 · Crib: MiniCribbs · Diagram: Keith Rose's Diagrams

- 1-8 1s set, 1L followed by partner casts 2 places, 1L crosses (below 3s) & casts up on Men's side to 2nd place facing down **while** 1M dances round 3L & up the middle to 2nd place Ladies' side facing down
- 9-16 2s+1s+3s dance Grand Chain, end with 2M & 1M facing out
- 17-24 2s+1s dance Ladies' Chain
- 25-32 2s+1s+3s Adv+Ret; 1s turn 1.1/2 RH to own sides. 213

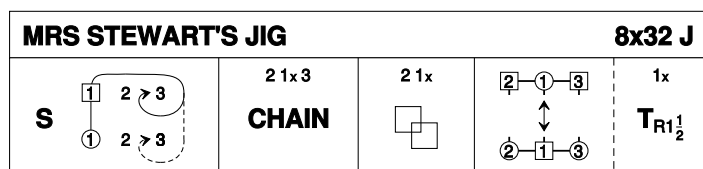

Frans Ligtmans, 1986, RSCDS Book 35.1

3C/4C longwise set.

16 REST AND BE THANKFUL R32 · 3/4L

Jack McConachie: Grampian Collection of Scottish Country Dances · Crib: MiniCribbs · Diagram: Keith Rose's Diagrams

- 1-8 1s cross RH & cast 1 place, cross LH & cast (Lady up & Man down) to meet 1st corners in prom hold
- 9-16 1s+1st corner dance 1/2 way round behind 2nd corner to 3rd corner **while** 2nd corners Adv+Ret diagonally;

1s leave 1st corners & turn 1.3/4 LH to meet 2nd corners in prom hold (1st corners now in diag opp place)
- 17-24 1s dance with 2nd corner person 1/2 way round to 4th corner **while** 1st corners Adv+Ret;

1s leave 2nd corners & turn 1.1/4 LH to face 1st corner (position)
- 25-32 1s dance 1/2 diag Reel of 4 with 1st corners, pass RSh & dance 1/2 diag Reel with 2nd corners to end on own sides 2nd place

