

Atholl SCDC - 21 April 26 - Kim's Programme

1 WELCOME TO THE ATHOLL J32 · 3/4L

Rhoda Purcell: 60th Anniversary of Atholl SCD Club · Crib: MiniCribbs · Diagram: Keith Rose's Diagrams

- 1-8 1s turn RH & cast (2s step up 3-4); 1s turn 1.1/2 RH to face 1st corners
- 9-16 2s+1s+3s dance reels of 3 across (1s & 1st corners pass RSh to begin). 1s end facing 1st corners
- 17-20 1s dance Corner Pass+Turn with 1st corners, pull back RSh, end BtoB 1L facing up, 1M facing down
- 21-24 1s dance Corner Pass+Turn with 4th corners, 1s ending in 2nd place own side
- 25-32 2s+1s+3s circle 6H hands round to left for 6 slip steps (3 bars), pivot (pull back LSh) and circle 6H back to right. 2 1 3

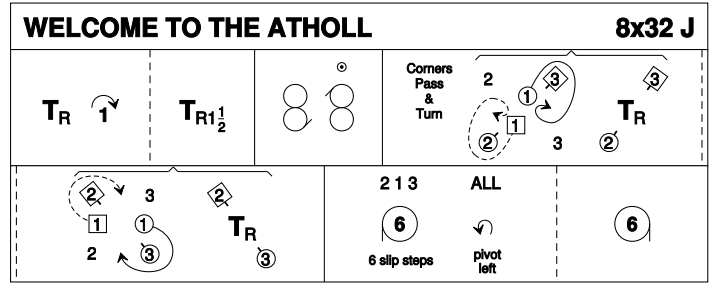

Rhoda Purcell, 60th Anniversary of Atholl SCD Club

3C/4C longwise set.

2 CATCH THE WIND R32 · 3/4L

Romaine Butterfield: RSCDS XLV 5 · Crib: MiniCribbs · Diagram: Keith Rose's Diagrams

- 1-8 1s set, cast 1 place & dance 1/2 Fig of 8 round 2s
- 9-16 1s set twice with 1L pulling back RSh on bars 11-12 to face out, 1L followed by partner casts up & dances down the middle 1L to face 3M while 1M faces 2M
- 17-24 1s RSh reels of 3 across (1M with 2s & 1L with 3s)
- 25-32 1L followed by partner dances down cast up round 3M & crosses to end in 2nd place on own sides, 1s turn RH (4 bars)

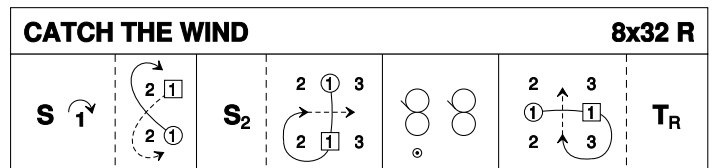

Romaine Butterfield, 1983, Island Bay Collection, RSCDS Book 45.5

3C/4C longwise set.

3 MISS ELEANOR S32 · 3/3L

Ann Dix: RSCDS XLIX 5 · Crib: MiniCribbs · Diagram: Keith Rose's Diagrams

- 1-8 1s+2s+3s dance Mirror (Reflection) reels of 3 on sides (1s in/down to start)
- 9-16 1s set, cast (2s step up) & turn RH. 1L casts to 3rd place, 1M casts up to 1st place (2M steps down & 3L steps up)
- 17-24 All dance 3 couple Bourrel:
 - 17-20 1M+3L also 2M+1L set advcg & 3/4 turn 2H to line up/down middle then pull back RSh turning to face own prtners as 3M & 2L chase anticl'wise to face them
 - 21-24 All set & turn 2H to own sides. 3 1 2
- 25-32 3s+1s+2s circle 6H round & back

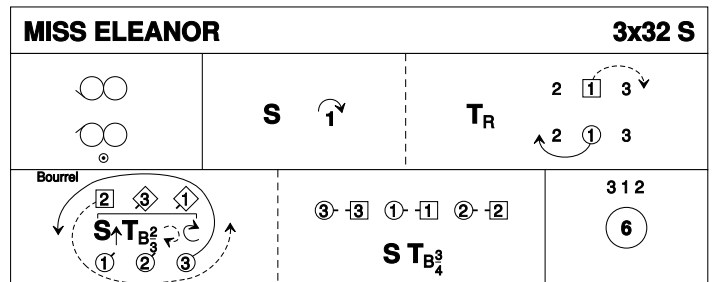

Ann Dix, 2013, RSCDS Book 49.5

3C/3C longwise set.

4 GLAYVA J32 · 2/4L

John Drewry: The Canadian Book of Scottish Country Dances · Crib: MiniCribbs · Diagram: Keith Rose's Diagrams

- 1-8 1s+2s dance 1/2 double Fig of 8, 1L+2L & 1M+2M turn on sides (Men LH Ladies RH)
- 9-16 1s+2s dance 1/2 double Fig of 8, 1L+2L & 1M+2M turn on sides (Men RH Ladies LH)
- 17-24 1s+2s dance RH across ending with dancers turning (individually) by the right to places & setting
- 25-32 1s+2s dance Espagnole: 1s+2s cross the set, (Ladies dancing RH joined, between Men), Ladies change places RH, 1s+2s cross back (Men dancing RH joined between Ladies) Men change places RH (1s+2s have now changed pstns), 2s turn RH & 1s turn LH

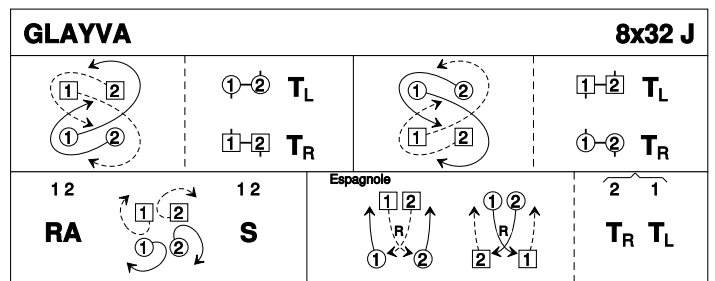

John Drewry, 1976, Canadian Book

2C/4C longwise set.

5 WE'VE NAE ELECTRIC R32 · 5/5L

Gary Coull: Jubilee Book 1929-2004 [Banffshire] · Crib: MiniCribbs · Diagram: Keith Rose's Diagrams

- 1-8 1s+3s cross down RH into double triangle position & set, dance round 1st corner into a line up/down middle facing partner
- 9-16 1s+3s dance RSh reel of 4 in centre **while** 2s+4s+5s dance LSh reels of 3 on sides (4M in & up, 4L in & down to start)
- 17-24 1s & 3s 1/2 turn partner RH, dance RSh round 2nd corner & turn partner RH 1.1/2 times to 2nd/4th place own sides
- 25-32 2s (at top) stand **while** 1s+4s also 3s+5s Set+Link; All turn RH to end 2 4 1 5 3

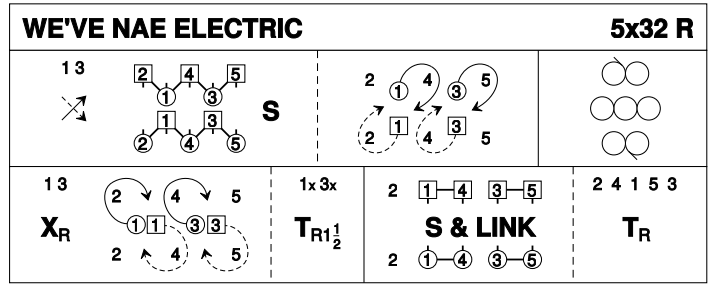

Gary Coull, Jubilee Book 1929-2004

5C/5C longwise set.

6 THE ORCHARDS OF CO. ARMAGH S32 · 3/3L

Jinty Anderson: RSCDS LIII 14 · Crib: MiniCribbs · Diagram: Keith Rose's Diagrams

- 1-8 1M leading 2M+3M also 3L leading 2L+1L chase clockwise 1/2 round to opp sides (4 bars). All set, 1s+3s turn partners 3/4 RH into line up/down (Men facing down)
- 9-12 3s+1s dance 1/2 reel of 4. Bar 12: 1M+3L pass LSH to face 2s (1M+2M & 3L+2L facing), 1L+3M remain in centre at top/bottom
- 13-16 1M+3L+2s dance 1/2 reel of 4 across. Bar 16: 1M & 3L pass LSh to face partners up/down set
- 17-24 1s+3s dance 1/2 reel of 4, 1M+3L pass LSh to face own partners. 3s+1s set, Petronella turn to own sides. 3 2 1
- 25-32 2s followed by 1s dance up to top, cast, 2s to 3rd place, 1s to 2nd place (4 bars). 3s+1s+2s turn partners 2H

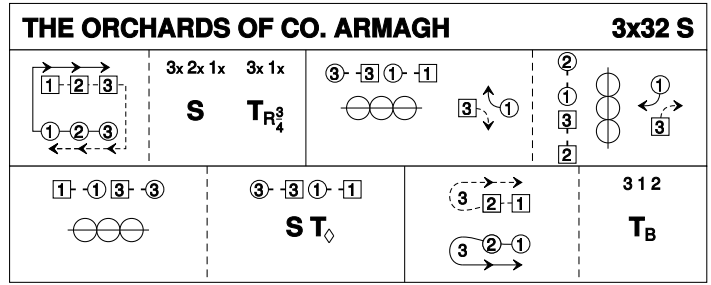

Jinty Anderson, RSCDS Book 53, Belfast Platinum Anniversary

3C/3C longwise set.

7 BEST SET IN THE HALL J32 · 3/4L

Helen Greenwood: RSCDS XLVI 7 · Crib: MiniCribbs · Diagram: Keith Rose's Diagrams

- 1-8 1s set & 1L followed by partner casts below 3s. 1L crosses & casts up to face her 1st corner **while** 1M dances up the middle to face 1st corner
- 9-12 1s set to 1st corners & dance RSh round each other into 3rd corner (pstn) **while** 1st corners dance in & turn right about to face their original position
- 13-16 1s+1st crnr person set & 1st crnr persons dance RSh round each other into diag opp crnrs **while** 1s dance in & pivot to right to face 2nd crnrs
- 17-24 1s repeat bars 9-16 with 2nd corners & end passing RSh to 2nd place opposite sides. (3)(1)(2)
- 25-32 3s+1s+2s chase clockwise 1/2 way & turn partners RH

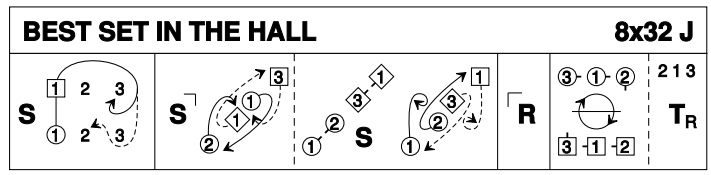

Helen Greenwood, 2003, RSCDS Book 46.7

3C/4C longwise set.

8 MRS MACPHERSON OF INVERAN R32 · 3/4L

John Drewry: Bon Accord Book of Scottish Country Dances · Crib: MiniCribbs · Diagram: Keith Rose's Diagrams

- 1-8 1s dance Inveran Reels with 2s+3s
- 9-16 1s turn RH 1.1/2 times moving down to 2nd place opp sides (2s step up); 1s cast up behind 2s & cross down to 2nd place own side
- 17-24 2s+1s+3s dance Grand Chain
- 25-32 2s+1s+3s circle 6H round & back

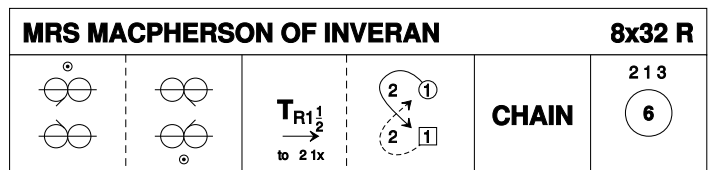

John Drewry, 1964, Bon Accord Book

3C/4C longwise set.

9 ROARING JELLY J32 · 3/4L

Hugh Foss: Scottish Dance Archives - The Donald Collection (Online List) · Crib: MiniCribbs · Diagram: Keith Rose's Diagrams

- 1-8 1s cross RH, cast 1 place, cross RH & cast (Man up & Lady down) into centre, 1M between 2s, 1L between 3s
- 9-16 1s+2s+3s circle 6H round & back (1s end in centre)
- 17-24 1s change places RH & dance out of ends to their right, into Figs of 8 (Lady round 2s as 1M dances round 3s)
- 25-32 1s dance reels of 3 on opposite sides giving RSh to 2nd corners & cross RH to places

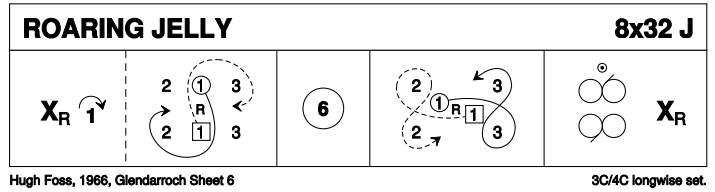

10 SUPERC-ALI-FRAGILISTIC R32 · 3/4L

Alison Austin: 60th Anniversary of Atholl SCD Club · Crib: SCDDDB Contributed Cribbs & Diagrams · Diagram: Keith Rose's Diagrams

- 1-4 1s set & cast 1 place
- 5-8 1L dances 1/2 fig 8 round 3M while 1M dances 1/2 fig 8 round 2L
- 9-16 1s turn RH 3/4, 1M+2s & 1L+3s set in lines across, all change places RH with opp person & chase 1/4 clockwise to sidelines
- 17-24 1s pass Lsh to dance 1/2 Diag reel of 4 with 1st corners, passing RSh dance 1/2 reel with 2nd corner positions to 2nd place opp sides.
- 25-28 1s turn LH 3/4 to 1L between 2L & 3L facing down, 1M between 2M and 3M facing up. All set in lines across.
- 29-32 All cross LH with opp person & chase 1/4 anticlockwise to 2, 1, 3

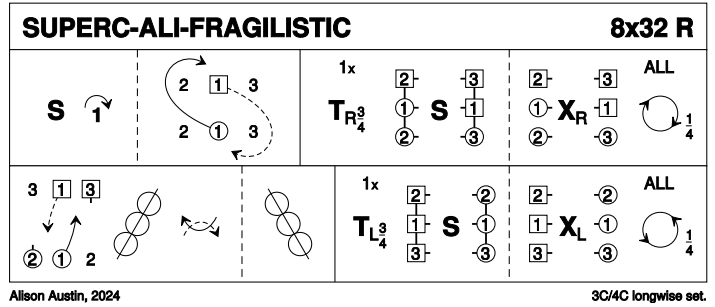

11 THE WATER OF LEITH S32 · 4/4L

John Wilkinson: RSCDS LIII 2 · Crib: MiniCribbs · Diagram: Keith Rose's Diagrams

- 1-8 1s+3s set. 1L dances down, casts up round 2M into middle facing down as 1M dances across, casts round 2L into middle facing up while 3s dance same round 4s. 1s+3s change places RH with partner into line of 4 in middle (M face down, L face up)
- 9-16 1s+3s dance reel of 4 in middle
- 17-20 1s+2s also 3s+4s dance RH across
- 21-24 1M followed by 1L casts round 2L to 2nd place own sides as 3M followed by 3L casts round 4L to 4th place (2s+4s step up 23-24)
- 25-32 1s+4s (middle couples) dance Espagnole
- 25-26 1s+4s cross (Ladies lead across RH passing between Men) with Ladies changing places RH
- 27-28 1s+4s cross back (Men lead across RH between Ladies) with Men changing places RH
- 29-32 4s turn RH as 1s turn LH

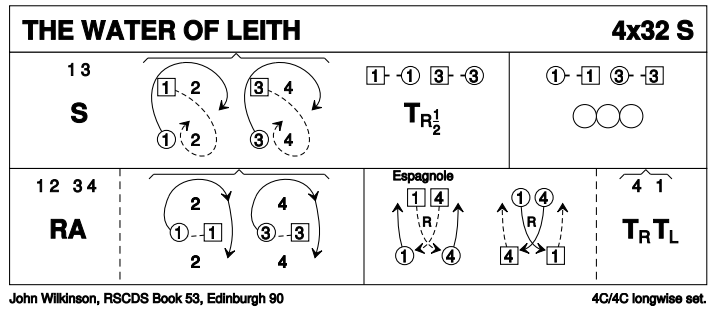

12 WELCOME TO AYR J32 · 3/4L

Jill Henriksen/Kathy Stewart: RSCDS XLVII 8 · Crib: MiniCribbs · Diagram: Keith Rose's Diagrams

- 1-8 1s+2s dance double Fig of 8 (1s cross down to start)
- 9-16 1s turn 2s on sides (Men RH, Ladies LH) & 1s dance down to turn 3s on sides (Men RH, Ladies LH) & 1s end facing 1st corners
- 17-24 1s dance 1/2 reel of 4 with corners & pass RSh to face 2nd corner, 1s dance 1/2 reel of 4 with crnrs & 1s end in middle LSh to LSh facing own sides
- 25-32 1M+3s (at top) also 1L+2s dance RH across (1s end in 2nd place opposite sides), all chase clockwise 1/2 way to own sides

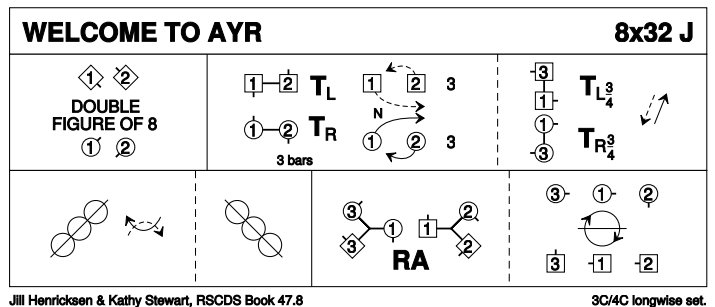

13 THE LOCHALSH REEL R40 · 3/4L

Pat Burnett: RSCDS LIII 1 · Crib: MiniCribs · Diagram: Keith Rose's Diagrams

- 1-8 1s turn RH, cast 1 place, cross LH, cast 1 place to meet partner in prom hold facing 3M (Lady on Man's left)
- 9-16 1s dance LSh reel of 3 across with 3s
- 17-24 1s separate to dance reels of 3 on opposite sides
- 25-32 1s dance NHJ up to top, turn 2s with other hand, cross down between 3s & cast up to 2nd place own sides
- 33-40 1s dance RH across (Lady with 2s & Man with 3s), pass RSh to dance LH across with other couple

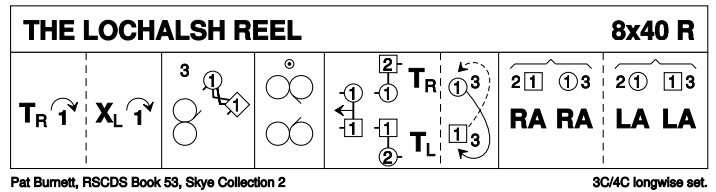

14 CHASING THE ECLIPSE S32 · 3/3L

Sandy Gallamore: The Highland Road Collection · Crib: MiniCribs · Diagram: Keith Rose's Diagrams

- 1-8 1s set, dance down below 3s (2s step up), cast up to 2nd place, pass LSh to face 1st corners
- 9-16 1s dance RSh reels of 3 on opposite sides, 1s end facing 1st corners
- 17-24 1s set to 1st corners, dance 3/4 round partner by RSh, 1s set to 2nd corners, dance round partner to own side, facing out
- 25-32 Promenade (Chaperoned) Chain progression:
 - 25-26 2s & 3s 3/4 turn partner RH into middle **while** 1s dance clockwise 1/4 round the set picking up 2L/3M ...
 - 27-30 who promenade 1/2 way clockwise **while** middle people (2M + 3L) turn LH 1.1/2.
 - 31-32 2s & 3s turn partner RH 3/4 to own sides **while** 1s dance clockwise 1/4 round to end in 2nd place. 3 1 2

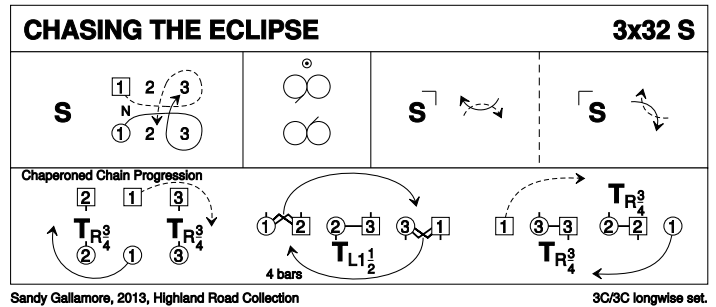

15 BIRLS ALLOWED J32 · 3/4L

Alex Taylor: Bannockburn 700 · Crib: MiniCribs · Diagram: Keith Rose's Diagrams

- 1-8 1s cross RH & cast 2 places (3s face down), 1s with 3s+2s dance 1/2 reflection reel of 3 (1s dancing in/up, 3s down/out, 2s in/down to start) (1) 3 2
- 9-16 1s cross down to dance full reels of 3 on own sides. 1 3 2
- 17-24 3s+2s (bottom 2 couples) Set & Rotate:
 - Set, rotate singly & dance on 1 place clockwise, change places RH on sides & dance on 1 place to own sides (3s in 2nd pl). 1 2 3
- 25-32 1s+2s dance 1/2 R&L, 2s+1s turn partner 1.1/2 times RH. 2 1 3

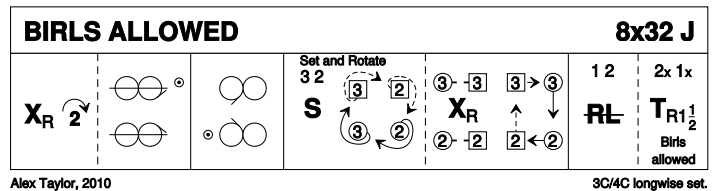

16 THE FINAL REEL R32 · 3/4L

Ian Barbour · Crib: MiniCribs · Diagram: Keith Rose's Diagrams

- 1-8 1s cross RH, cast 1 place & turn LH 1.1/4 times to end 1M between 2s & 1L between 3s
- 9-16 2s+1s+3s Set+Link for 3 twice. 1s end facing 1st corners pstns
- 17-24 1s dance 1/2 reel of 4 with 1st corners (pstrn) & 1/2 reel with 2nd corners (pstrn), 1s cross to 2nd place own sides
- 25-32 2s+1s+3s circle 6H round & back

