

Atholl SCDC - 18 March 25 - Robin's Programme

1 GOOD HEARTED GLASGOW J32 · 3/4L

Peter Knapman: A Guide to Scottish Country Dancing (ex-Collins) · Crib: MiniCribs · Diagram: Keith Rose's Diagrams

- 1-8 1s turn RH & cast to 2nd place, turn partner LH 1.1/4 times
- 9-16 1s dance RH across (Lady with 2s at top & Man with 3s); 1s pass RSh & dance LH across with other couple
- 17-24 1s lead down the middle & back to 2nd place own side
- 25-32 2s+1s+3s circle 6H round & back

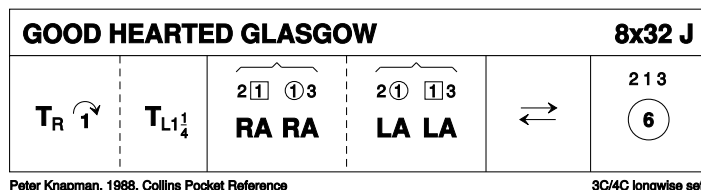

2 THE FALLS OF ROGIE R32 · 3/4L

Jean Attwood: Alexander Dances Book 1 · Crib: MiniCribs · Diagram: Keith Rose's Diagrams

- 1-8 1s cross RH & cast 1 place, 1s cross RH & cast 1 place (Man up, Lady down)
- 9-16 1s dance 1/2 reels of 3 across (1M with 2s & 1L with 3s), set in lines across & change places RH with opposite person
- 17-24 2s+1s+3s chase clockwise 1/2 way, 1s dance in & turn 1.1/4 RH to face 1st corner positions as 2s & 3s continue to chase on to places (as bar 16)
- 25-32 1s dance 1/2 reel of 4 with 1st corners, passing RSh dance 1/2 reel with 2nd corners & cross passing RSh to 2nd place own sides

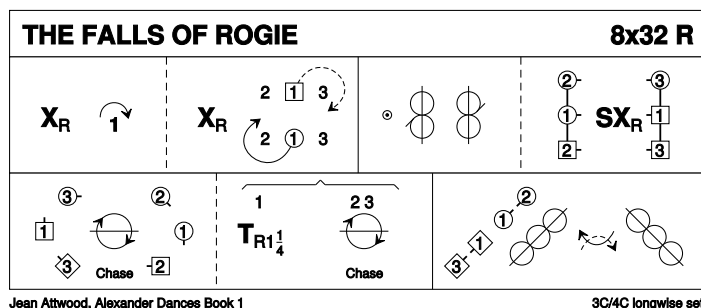

3 ATHENS OF THE NORTH S32 · 3/4L

Atsuko Clement: 90 - Twelve anniversary dances celebrating ninety years of RSCDS Edinburgh Branch 5 · Crib: MiniCribs · Diagram: Keith Rose's Diagrams

- 1-8 2s followed by 1s dance down (2 steps), turn partners 2H. 1s followed by 2s dance up, 1s+2s 1/2 turn (M Left hand, L Right hand) 2 1 3
- 9-16 2s+1s+3s dance Diag R&L. 1s finish facing out in 2nd place (3) 1 (2)
- 17-24 3s+1s+2s dance RSh reels of 3 on sides (1M+3L & 1L+2M pass RSh to start)
- 25-32 3s+1s+2s dance clockwise 1/2 way round & turn partners 2H (1s turn 1.1/2 times) Order: 2 1 3

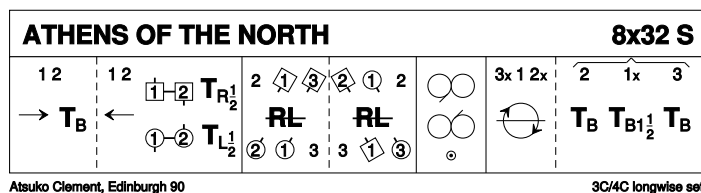

4 IAN POWRIE'S FAREWELL TO AUCHTERARDER J128 · 4S

Bill Hamilton: *Thirty Popular Dances, Volume Two* · Crib: *MiniCrib*s · Diagram: Keith Rose's Diagrams

- 1-8** All circle 8H round to the left & back (popular variation - 8 hands all the way round to left)
- 9-24** Ladies dance in front of ptrn & behind next Man, into RH across, in front of Man opp own ptrn & behind next Man, into RH across & back to place
- 25-32** All Promenade clockwise
- 33-40** 1s & 3s dance cl'wise behind next couple & Men dance past cpl as Ladies dance in between cpl & both turn R to face cpl, all set & turn RH
- 41-48** All dance parallel reels of 4
- 49-56** 1s & 3s dance a full Fig of 8 round the standing 2s/4s
- 57-64** 1s & 3s dance LH across, 1s & 3s dance back to places (Men round & Ladies through the standing 2s & 4s)
- 65-96** 2s & 4s repeat 33-64
- 97-104** All Promenade anticlockwise
- 105-120** Men dance in front of ptrn & behind next Lady, into LH across, dance in front of Lady opp own partner & behind next L into LH across & back to pl
- 121-128** All circle 8H round to the right & back (popular variation - 8 hands all the way round to right)

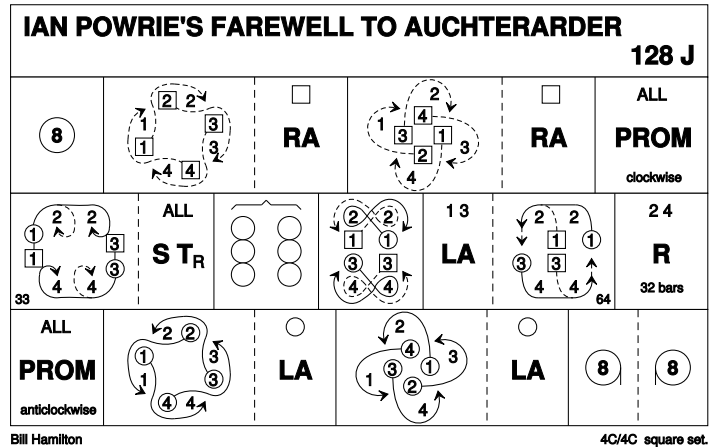

5 BURNIEBOOZLE R32 · 3/4L

David G Queen: *Southport Book Volume 1* · Crib: *MiniCrib*s · Diagram: Keith Rose's Diagrams

- 1-8** 1s set & cast 1 place, turn partner LH 1.1/2 times to opposite sides (M facing up L down)
- 9-16** 2s+1s+3s dance reel of 3 on sides giving LSh to 2nd corner & ending with 1s turning RH to face 1st corners
- 17-28** Dance to Corners & Set: (12 bars)
- Couple in middle change places with corners passing RSh, corners pass RSh in middle with a 1/4 turn to right to face next corner **while** supporting corners set (2 bars). Repeat 5 more times to end with corners in diagonally opposite place and 1s meet again in middle
- 29-32** 1s turn RH 1.1/2 times to 2nd place own sides **while** 2s & 3s change places RH on the sides & cross over LH

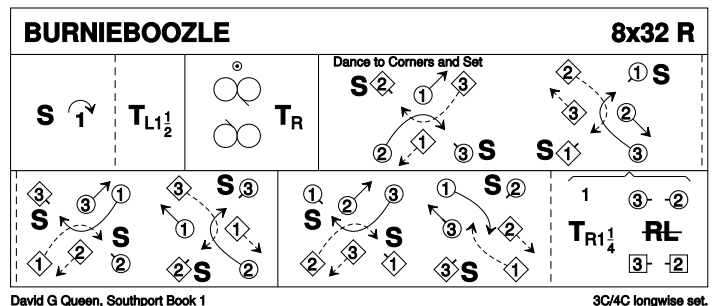

6 GEBURTSTAG IN WIEN S32 · 3/4L

David I Hall · Crib: MiniCribbs · Diagram: Heiko's Diagrams

- 1-8 1s+2s+3s set, cross RH with partner; circle 6H 1/2 round to left. 3 2 1
- 9-16 2s+1s dance The Knot
- 17-24 3s+1s+2s Set+Link for 3 to end 1M between 2s facing down, 1L between 3s facing up; 2s & 3s set twice **while** 1s set & Petronella turn to 2nd place own side
- 25-32 2s+1s Poussette

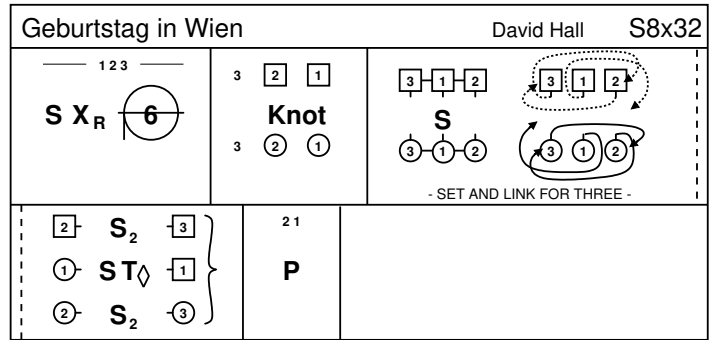

7 BEST SET IN THE HALL J32 · 3/4L

Helen Greenwood: RSCDS XLVI 7 · Crib: MiniCribbs · Diagram: Keith Rose's Diagrams

- 1-8 1s set & 1L followed by partner casts below 3s. 1L crosses & casts up to face her 1st corner **while** 1M dances up the middle to face 1st corner
- 9-12 1s set to 1st corners & dance RSh round each other into 3rd corner (pstrn) **while** 1st corners dance in & turn right about to face their original position
- 13-16 1s+1st crnr person set & 1st crnr persons dance RSh round each other into diag opp crnrs **while** 1s dance in & pivot to right to face 2nd crnrs
- 17-24 1s repeat bars 9-16 with 2nd corners & end passing RSh to 2nd place opposite sides. (3)(1)(2)
- 25-32 3s+1s+2s chase clockwise 1/2 way & turn partners RH

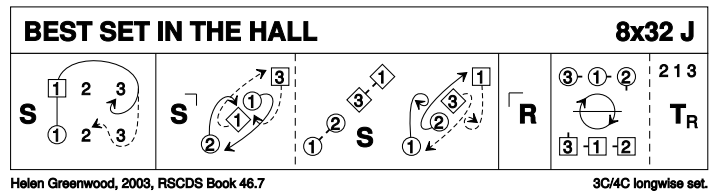

8 WE'VE NAE ELECTRIC R32 · 5/5L

Gary Coull: Jubilee Book 1929-2004 [Banffshire] · Crib: MiniCribbs · Diagram: Keith Rose's Diagrams

- 1-8 1s+3s cross down RH into double triangle position & set, dance round 1st corner into a line up/down middle facing partner
- 9-16 1s+3s dance RSh reel of 4 in centre **while** 2s+4s+5s dance LSh reels of 3 on sides (4M in & up, 4L in & down to start)
- 17-24 1s & 3s 1/2 turn partner RH, dance RSh round 2nd corner & turn partner RH 1.1/2 times to 2nd/4th place own sides
- 25-32 2s (at top) stand **while** 1s+4s also 3s+5s Set+Link; All turn RH to end 2 4 1 5 3

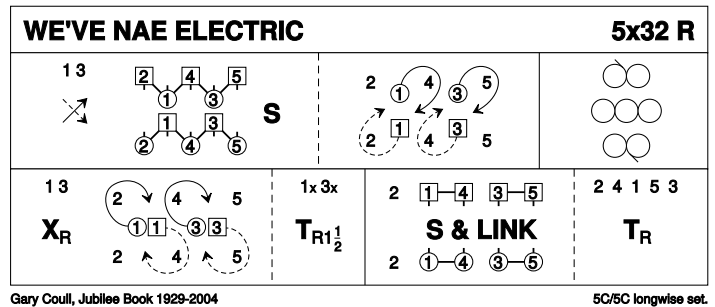

9 GLASTONBURY TOR R32 · 3/4L

Duncan Brown: RSCDS XLVII 11 · Crib: MiniCribs · Diagram: Keith Rose's Diagrams

- 1-8** 1s+2s set & dance 1/2 RH across, 1s+3s set & dance 1/2 LH across
- 9-16** 1s set & cross RH, 1s cast up 1 place & turn LH turn to face 1st corners (pstns)
- 17-20** 1s dance 1/2 reel of 4 with 1st cnrns (pstns) & pass left to face 2nd cnrns (pstns)
- 21-24** 1s dance 1/2 reel of 4 with 2nd cnrns (pstns) & curve right to end 1M between 3s facing down & 1L btwn 2s facing up
- 25-32** 1M+3s also 1L +2s Set+Link for 3 once, 1s turn RH 1.1/2 times to 2nd place as 2s & 3s dance clockwise 1/2 way to places 2 1 3

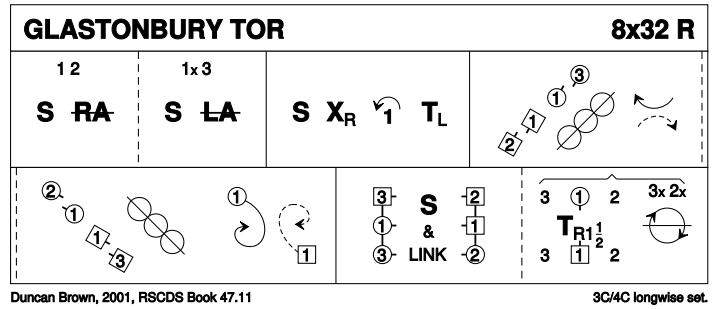

10 MACLEOD'S FANCY J32 · 4/4L

John Drewry: RSCDS XXXIII 3 · Crib: MiniCribs · Diagram: Keith Rose's Diagrams

- 1-8** 1s+4s set diagonally, 1M+4L 3/4 turn RH & cast up/down own side back to place **while** 1L+4M cast down/up own side & 3/4 turn RH back to place
- 9-16** All dance reels of 4 on sides, ending as at start of reel
- 17-24** 2s & 3s turn 1s & 4s RH into a St Andrew's Cross, all set & turn cnrns to end 1s in 3rd pl & 4s in 2nd pl on own sides having passed other cnrn RSh
- 25-32** 1s & 4s set & cross over (Ladies dancing between Men) & dance 1/2 Fig of 8 round end couples to 3rd/2nd places (giving RH at top, LH at bottom)

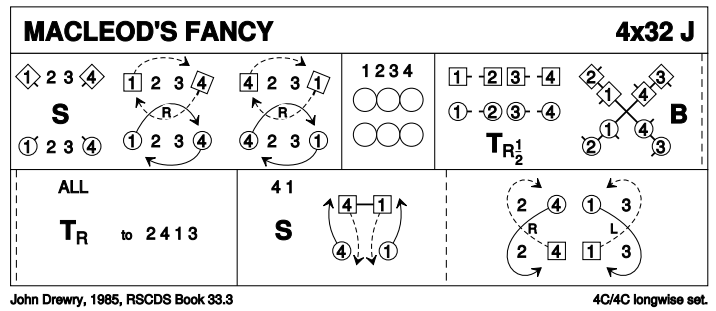

11 ADIEU MON AMI S32 · 3/4L

RSCDS XXIV 11 · Crib: MiniCribs · Diagram: Keith Rose's Diagrams

- 1-8** 1s+2s set on sides, turn 2H, set to partners & turn 2H into Allemande hold
- 9-16** 1s+2s Allemande 1s end facing 1st corners
- 17-24** 1s dance 'Hello-Goodbye' setting, into middle facing partner, clap & petronella turn to 2nd place
- 25-32** 2s+1s+3s circle 6H round & back

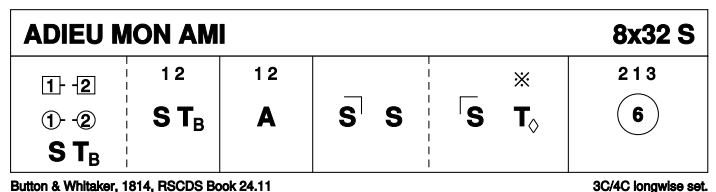

12 KAMO KAROUSEL J32 · 3/4L

Eddy West: *The Whangarei Book of Scottish Country Dances* · Crib: *MiniCrib*s · Diagram: *Keith Rose's Diagrams*

- 1-8 1s cross RH & cast 1 place, 1s dance 1/2 Figs of 8 (1L round 2s, 1M round 3s) **while** 2s+3s set & cross LH. (2)1(3)
- 9-16 1s dance Diag R&L. 3 1 2
- 17-24 3s+1s+2s Set & Rotate for 3 couples:
All set & chase clockwise into lines across facing partner, all change places with partner & chase clockwise to own sides. 2 1 3
- 25-32 2s+1s+3s circle 6H round & back

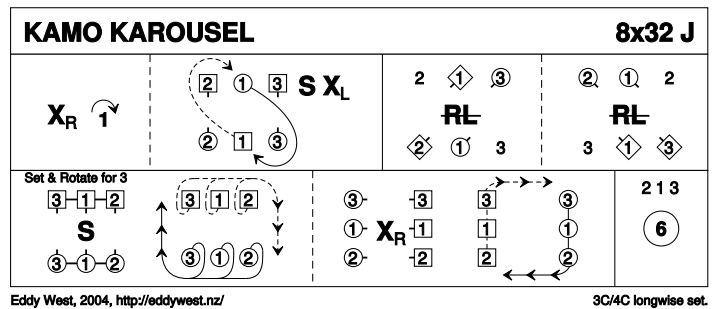

13 THE PEAT FIRE FLAME R40 · 3/4L

John Drewry: *Bon Accord Book of Scottish Country Dances* · Crib: *MiniCrib*s · Diagram: *Keith Rose's Diagrams*

- 1-8 1s cast 1 place & dance 1/2 Fig of 8 round 2s & turn 3/4 LH to face 1st corners
- 9-16 1s turn 1st corner RH, pass partner RSh & turn 2nd corner LH pass partner LSh to face 1st corners
- 17-24 1s dance 1/2 diagonal reel of 4 with 1st corners & 1/2 diagonal reel with 2nd corners to end in centre BtoB facing 3rd corners (1st corner persons)
- 25-32 1s set to 3rd corners & dance round one another clockwise to 4th corners, set & dance clockwise to face out on opposite sides
- 33-40 1s dance out & cast round 1st corner into centre **while** 2s & 3s dance 1/2 R&L, 2s+1s+3s turn RH

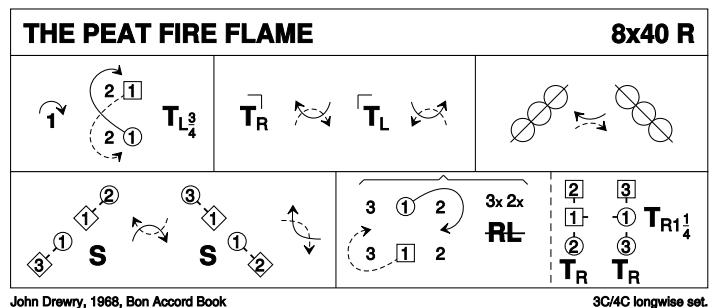

14 THE GARRY STRATHSPEY S32 · 4/4L

James B Cosh: *Twenty Two SCD* · Crib: *MiniCrib*s · Diagram: *Keith Rose's Diagrams*

- 1-8 1s+2s & 3s+4s dance 1/2 R&L, 1s+4s (middle couples) dance 1/2 R&L
- 9-16 2s+4s & 1s+3s circle 4H left 1/2 way, 2s+3s (middle couples) circle 4H right 1/2 way; 1s dance up to top (2s+3s+4s step down) & all face as for Reel of 4 on sides
- 17-24 All set HS & dance 1/2 Grand Chain. All end on own side 2 3 4 1
- 25-32 All dance Reel of 4 on sides. 2 3 4 1

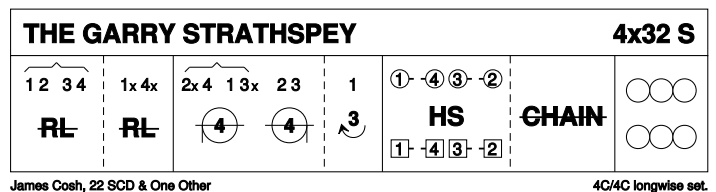

15 NAPIER'S INDEX J40 · 3/4L

Brian Charlton: RSCDS XLV 8 · Crib: MiniCrib · Diagram: Keith Rose's Diagrams

- 1-8** 1s set & cast 1 place, turn LH 1.1/4 times to end in Bal-in-Line position between 1st corners
- 9-16** 1s+1st corners Bal-in-Line & turn corners RH (4 bars) to Bal-in-Line again with 1st corners
- 17-24** 1s dance reel of 3 on sides (LSh to 2nd corner) & end diagonally between 2nd corners
- 25-32** 1s+2nd corners Bal-in-Line & turn corners RH (4 bars), Bal-in-Line again with 2nd corners
- 33-40** 1s dance reels of 3 across (LSh to 3rd corners) & cross RH to 2nd places

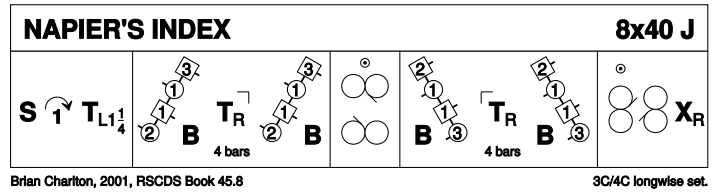

16 THE FINAL REEL R32 · 3/4L

Ian Barbour · Crib: MiniCrib · Diagram: Keith Rose's Diagrams

- 1-8** 1s cross RH, cast 1 place & turn LH 1.1/4 times to end 1M between 2s & 1L between 3s
- 9-16** 2s+1s+3s Set+Link for 3 twice. 1s end facing 1st corners pstns
- 17-24** 1s dance 1/2 reel of 4 with 1st corners (pstn) & 1/2 reel with 2nd corners (pstn), 1s cross to 2nd place own sides
- 25-32** 2s+1s+3s circle 6H round & back

