

# Atholl SCDC 1 Oct 2024 Alison A's Programme

## 1 JOIE DE VIVRE J32 · 3/4L

Irene van Maarseveen: RSCDS XXXIX 2 · Crib: MiniCribbs · Diagram: Keith Rose's Diagrams

- 1-8 1s set, cast 1 place, 1s dance down between 3s & cast back to 2nd place on own sides
- 9-16 2s+1s+3s turn RH & chase 1/2 way round clockwise
- 17-24 3s+1s+2s dance DoSiDo, set & 1/2 turn partners RH for Allemande
- 25-32 3s+1s+2s dance Allemande

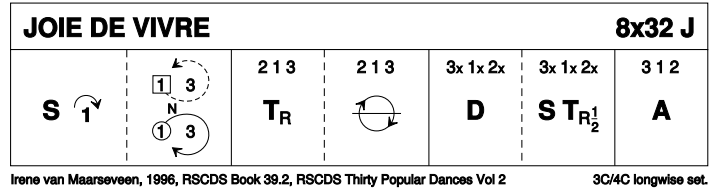

## 2 HAPPY RETURNS R32 · 3/4L

Miss Milligan's Miscellany of Scottish Country Dances · Crib: MiniCribbs · Diagram: Keith Rose's Diagrams

- 1-8 1s cross down to dance reflection reels of 3 on opposite sides
- 9-16 1s cross down to dance reflection reel of 3 on own sides
- 17-24 1s lead down the middle for 3 steps & back, cast to 2nd place
- 25-32 1s dance RH across with 3s & LH across with 2s

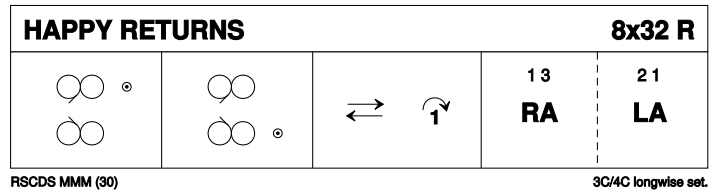

## 3 THE MINISTER ON THE LOCH S32 · 3/3L

Roy Goldring: Magazine Dances 2005-2009 · Crib: MiniCribbs · Diagram: Keith Rose's Diagrams

- 1-8 1s+2s dance Diamond Poussette
- 9-16 1s dance down for 2 steps, turn 2H, dance up to top & turn 2H remaining in centre facing up
- 17-24 1s+3s dance double Fig of 8 round 2s with 1s casting to start
- 25-32 1M+2M turn LH 1.1/2 times while 1L+2L turn RH 1.1/2 times, 1M+3M turn RH 1.1/2 times while 1L+3L turn LH 1.1/2 times

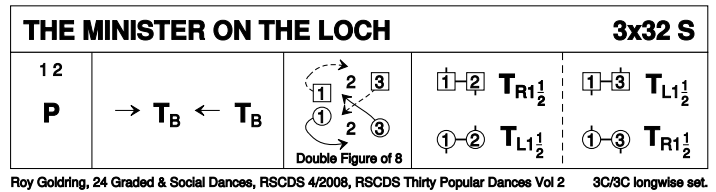

## 4 THE CHEQUERED COURT J32 · 3/4L

Duncan Brown: RSCDS XLII 3 · Crib: MiniCribbs · Diagram: Keith Rose's Diagrams

- 1-8 1s cross RH, cast 1 place (2s step up), 1s dance 1/2 Figs of 8 (Man round 2s & Lady round 3s) & end facing 1st corners
- 9-16 1s dance Pass+Turn with 1st corners & 1s twirl round in centre to face 4th cnrns, 1s dance Pass+Turn with 4th cnrns & twirl round to BtoB facing own sides
- 17-24 1s dance 6 bars of Double Triangles & end with Petronella turn to 1L between 2s facing 2L & 1M between 3s facing 3M
- 25-32 1s dance reel of 3 across giving RSh to 4th corners (6 bars) & 1s cross RH to own sides

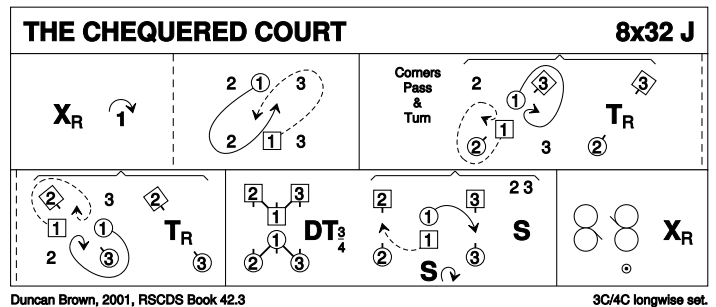

## 5 MILTON'S WELCOME R32 · 3/4L

John Bayly: RSCDS XXXIII 8 · Crib: MiniCribbs · Diagram: Keith Rose's Diagrams

- 1-8 1s+2s+3s set, cross RH, 1s+2s+3s set & 1s+3s 3/4 turn RH (to form line up & down centre) as 2s cross RH to original places
- 9-16 1s+3s dance reel of 4 in centre of dance end with 1L+3M taking LH as partners end on sides
- 17-24 1L+3M 3/4 turn LH to face own sides, dance out & cast behind 2s to original places, 1s+2s+3s turn LH
- 25-32 1s+2s dance Poussette. 2 1 3

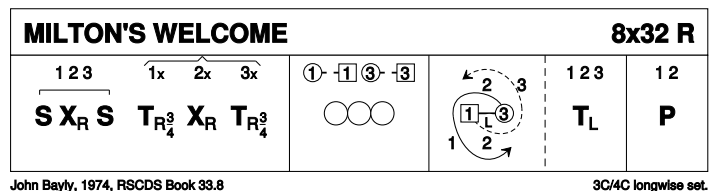

**6 LINNEA'S STRATHSPEY** S32 · 3/4L  
 Tim Wilson: RSCDS XLVII 2 · Crib: MiniCribs · Diagram: Keith Rose's Diagrams

- 1-8 1s set & cast 1 place, 1s cross passing LSh & cast RSh round 1st corners into face them
- 9-16 1s dance 'Hello-Goodbye' setting & end passing RSh to face out in 2nd place own sides
- 17-24 Promenade (Chaperoned) Chain progression:  
**17-18** 2s & 3s 3/4 turn partner RH into middle **while** 1s dance clockwise 1/4 round the set picking up 2L/3M ...  
**19-22** who promenade 1/2 way clockwise **while** middle people (2M + 3L) turn LH 1.1/2.  
**23-24** 2s & 3s turn partner RH 3/4 to own sides **while** 1s dance clockwise 1/4 round to end in 2nd place, all 3 couples in middle facing up 3 1 2
- 25-32 3s+1s+2s dance Allemande

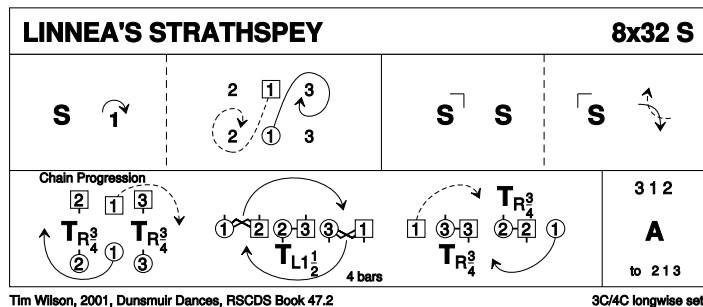

**7 CHASED LOVERS** J32 · 3/4L  
 Tim Wilson: RSCDS LIII 9 · Crib: MiniCribs · Diagram: Keith Rose's Diagrams

- 1-4 1s set, cross down (no hands) to 2nd place facing out (2s step up 3-4)
- 5-8 1s cast down behind 3s, meet & dance up centre with 1L leading, 1M following, to face 2M (her 1st corner)
- 9-16 1s, in tandem, dance LSh reel of 3 on 1st corner diagonal (out of top of set to start), finishing by 1s pulling back RSh to face down, 1M leading, facing 3M
- 17-24 1s, in tandem, dance RSh reel of 3 on 2nd corner diagonal (out bottom of set to start), finishing with 1s facing own 1st corners
- 25-32 1s dance Pass+Turn with 1st corners, (pass RSh), Pass+Turn with 2nd corners, finishing passing RSh to 2nd place own sides

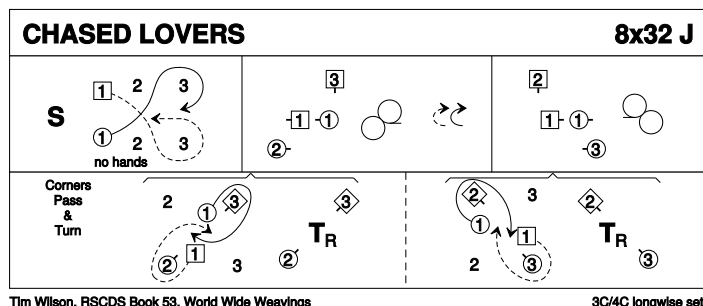

**8 WE'VE NAE ELECTRIC** R32 · 5/5L  
 Gary Coull: Jubilee Book 1929-2004 [Banffshire] · Crib: MiniCribs · Diagram: Keith Rose's Diagrams

- 1-8 1s+3s cross down RH into double triangle position & set, dance round 1st corner into a line up/down middle facing partner
- 9-16 1s+3s dance RSh reel of 4 in centre **while** 2s+4s+5s dance LSh reels of 3 on sides (4M in & up, 4L in & down to start)
- 17-24 1s & 3s 1/2 turn partner RH, dance RSh round 2nd corner & turn partner RH 1.1/2 times to 2nd/4th place own sides
- 25-32 2s (at top) stand **while** 1s+4s also 3s+5s Set+Link; All turn RH to end 2 4 1 5 3

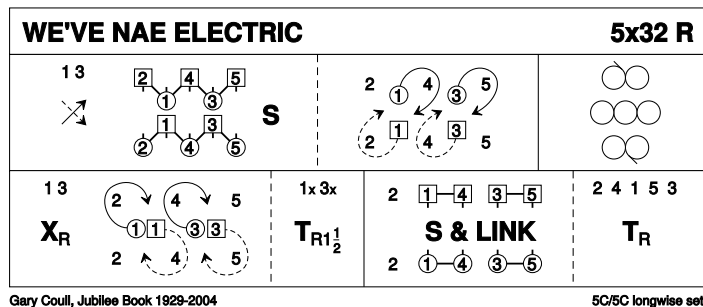

**9 CENTENARY JIG** J32 · 3/4L  
 Anne Thorn: Glasgow Branch 100th Anniversary Dances · Crib: MiniCribs · Diagram: Keith Rose's Diagrams

- 1-8 1s set, cast below 3s, meet & dance up to the middle of 2nd place. 2s step up bars 5-6.
- 9-16 2M+1M turn LH **while** 2L+1L turn RH. 1M+3M & 1L+3L turn with other hand to finish 1s back to back facing 1st corners
- 17-24 1s turn 1st corners RH, pass RSh, turn 2nd corners RH, pass RSh to finish 2nd place own sides
- 25-32 2s+1s+3s circle 6H round & back

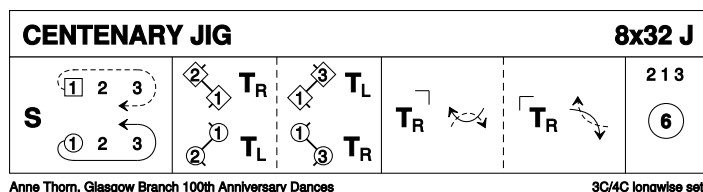

## 10 THE WESTMINSTER REEL R32 · 2/4L

Jeremy Hill: RSCDS XLV 1 · Crib: MiniCribbs · Diagram: Keith Rose's Diagrams

- 1-8 1M+2L turn RH, 1L+2M turn RH 1.1/2 times end facing partner ready for diagonal reel of 4
- 9-16 1s+2s dance diagonal reel of 4. All end in original places
- 17-24 1s+2s Set & Rotate :  
Set (facing diagonally opp dancer), rotate singly & dance on 1 place clockwise, change places RH on sides & dance on 1 place to own sides (1s in 2nd pl)
- 25-32 2s+1s dance R&L

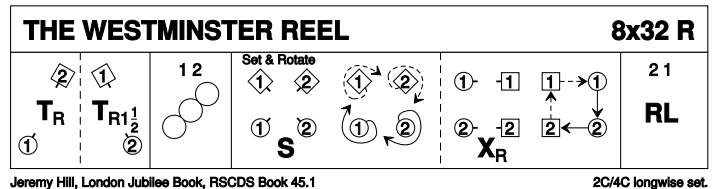

## 11 THE BELLE OF BON ACCORD S32 · 4/4L

John Drewry: Deeside Book Part 2 · Crib: MiniCribbs · Diagram: Keith Rose's Diagrams

- 1-8 1L & 3L cross down 1 pl & cast up on opp side into centre as 1M & 3M dance across & cast down into centre, 1s+2s & 3s+4s dance RH across
- 9-16 1s & 3s dance reel of 4 up & down centre of dance
- 17-24 1s & 3s 3/4 turn RH to face up while 2s & 4s dance up on sides & turn in to face down & all set, all circle 4H round to left & end on sides
- 25-32 1s & 3s lead up between 2s/4s crossing over & cast down 1 place, 1s & 3s turn 2H & 1s dance down to 4th place as 3s cast up on own sides to 2nd pl

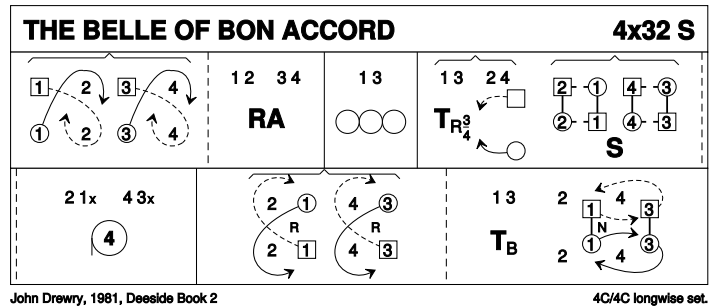

## 12 MAJOR IAN STEWART J32 · 3/4L

John Drewry: RSCDS XXXV 4 · Crib: MiniCribbs · Diagram: Keith Rose's Diagrams

- 1-8 1s+2s 1/2 turn partners RH & dance RH across 1/2 way, 2s+1s full turn partner RH ending with 2s at top & 1s in 2nd place
- 9-16 2s+1s+3s dance reels of 3 on own sides (1L dances in & up as 1M dances in & down to start) & 1s end facing 1st corners
- 17-24 1s dance 'Hello-Goodbye' setting ending with petronella turn to 2nd places
- 25-32 2s+1s+3s circle 6H round to the left for 6 steps, pivot & chase back to places

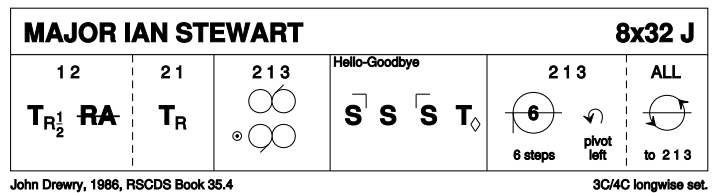

## 13 BRATACH BANA R32 · 3/4L

John Drewry: Thirty Popular Dances, Volume Two · Crib: MiniCribbs · Diagram: Keith Rose's Diagrams

- 1-8 1s turn RH & cast 1 place (2s step up); 1s dance LSh round 1st corners to 2nd place opp side facing 2nd corners
- 9-16 1s dance 1/2 RSh reel of 3 on sides & dance 1/2 LSh reel of 3 across (1M with 3s at top, 1L with the 2s, LSh to 3rd corner position)
- 17-24 1s turn 3/4 LH, turn 3rd corner (pstn) RH & pass RSh to turn 4th corner (pstn) RH ending in 2nd pl own side in prom hold with 4th corner (pstn)
- 25-32 1s+corners promenade diagonally across (passing RSh) to diag opp corner & 1/2 turn to end 1s in 2nd pl opp side, 1s dance 1/2 Diag R&L (M up, L down). End 2 1 3

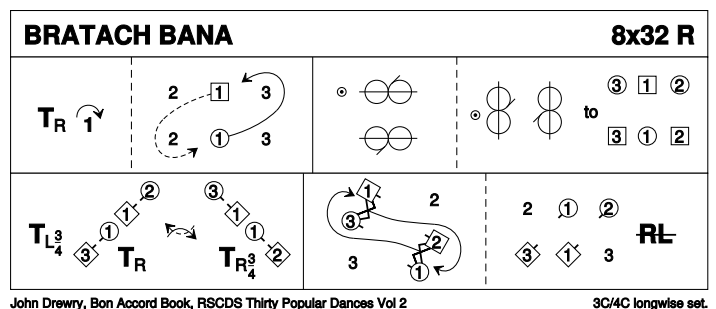

## 14 CITY OF BELFAST S32 · 3/3L

Lucy Mulholland: RSCDS XLVIII 6 · Crib: MiniCrib · Diagram: Keith Rose's Diagrams

- 1-8 1s dance 1/2 Fig of 8 round 2s, 1L+2M turn RH 1.1/4 times **while** 1M+2L turn LH 1.1/4 times & 1s end BtoB facing opp sides
- 9-16 1s+2s dance reel of 4 across in 2nd place. 2s end in 1st places **while** 1s pass LSh to face 1st corners
- 17-24 1s set to 1st corner & 2nd corner ending (turning to right) between corners, all set & 1s cross RH
- 25-32 1s+3s dance Espagnole:
  - 25-26 1s+3s cross (Ladies lead across RH passing between Men) with Ladies changing places RH
  - 27-28 1s+3s cross back (Men lead across RH between Ladies) with Men changing places RH
  - 29-32 3s turn RH as 1s turn LH to end 2 3 1

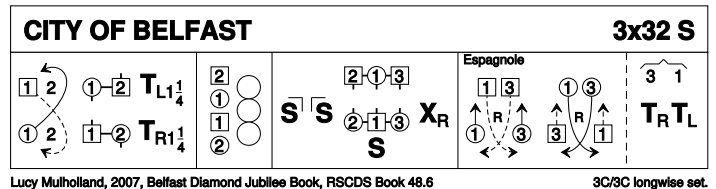

## 15 THE LUCKENBOOTH BROOCH J32 · 3/4L

John Bowie Dickson: RSCDS LIII 6 · Crib: MiniCrib · Diagram: Keith Rose's Diagrams

- 1-8 1s in prom hold (Lady on Man's left) dance reel of 3 with 2s (RSh to 2M) & end facing 3M
- 9-16 1s dance reel with 3s (RSh to 3M) ending with 1s dancing into centre facing Men's side
- 17-24 1M casts up & 1L dn into centre & dance out Ladies' side, 1M cast up & 1L dn to end 1M b'tw'n 2s facing dn & 1L+3s face up as 2s+3s dance R&L
- 25-32 2s+1s+3s set twice, 1s turn RH 1.3/4 times to 2nd places

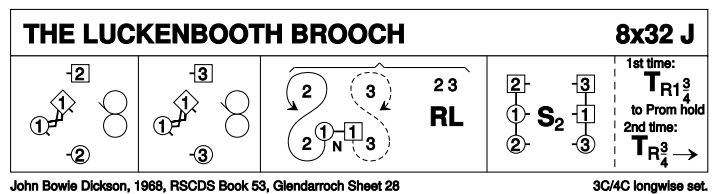

## 16 MRS MACPHERSON OF INVERAN R32 · 3/4L

John Drewry: Bon Accord Book of Scottish Country Dances · Crib: MiniCrib · Diagram: Keith Rose's Diagrams

- 1-8 1s dance Inveran Reels with 2s+3s
- 9-16 1s turn RH 1.1/2 times moving down to 2nd place opp sides (2s step up); 1s cast up behind 2s & cross down to 2nd place own side
- 17-24 2s+1s+3s dance Grand Chain
- 25-32 2s+1s+3s circle 6H round & back

