

Atholl SCDC - 23 April 2024 Kim's Programme

1 GAELFORCE WIND J32 · 3/4L

Derek Haynes: A Third Book of Graded Scottish Country Dances · Crib: MiniCribbs · Diagram: Keith Rose's Diagrams

- 1-8 1s set, cross RH, 1s+2s Set+Link (Ladies face out)
- 9-16 2s+1s Men's Chain
- 17-24 1s 1/2 Figs of 8 (L round 2s & M round 3s), 2s+1s+3s turn RH & open into
- 25-32 2s+1s+3s circle 6H round & back

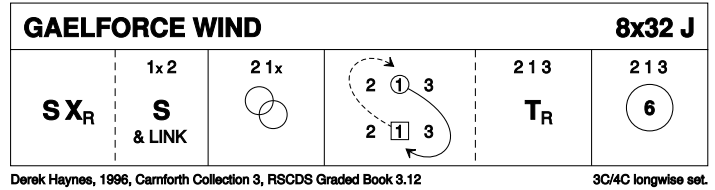

2 THE HIGHLAND LASS R32 · 3/4L

Playford: RSCDS XXX 3 · Crib: MiniCribbs · Diagram: Keith Rose's Diagrams

- 1-8 1s dance in & cast 1 place, 1s dance 1/2 reels of 3 across (Lady with 2s & Man with 3s)
- 9-16 1s dance down between 3s, cast up to 2nd place opposite sides & dance 1/2 reels of 3 across (Man with 2s & Lady with 3s)
- 17-24 2s+1s dance R&L
- 25-32 1s dance down between 3s, cast up to 2nd place & 2s+1s+3s turn RH

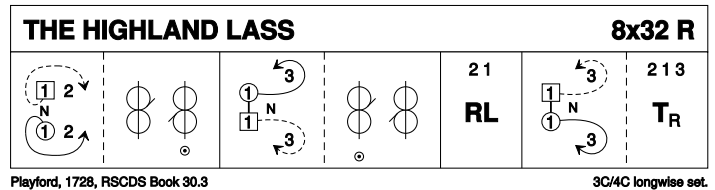

3 FOXHILL COURT S32 · 3/4L

John Drewry: The Canadian Book of Scottish Country Dances · Crib: MiniCribbs · Diagram: Keith Rose's Diagrams

- 1-8 1s+2s dance Espagnole:
 - 1-2 1s+2s cross (Ladies lead across RH passing between Men) with Ladies changing places RH
 - 3-4 1s+2s cross back (Men lead across RH between Ladies) with Men changing places RH
 - 5-8 2s turn RH as 1s turn LH to face 1st corners
- 9-20 Dance to Corners & Set: (12 bars)

Couple in middle change places with corners passing RSh, corners pass RSh in middle with a 1/4 turn to right to face next corner **while** supporting corners set (2 bars). Repeat 5 more times to end with corners in diagonally opposite place and 1s meet again in middle & pass RSh to face 3rd corner positions
- 21-24 1s turn 3rd corners 2H to face diagonally in (corners on 1s right) & set **while** 2nd corners set & cross RH
- 25-32 1s+3rd corners Adv+Ret & dance 3/4 RH across to end 2 1 3

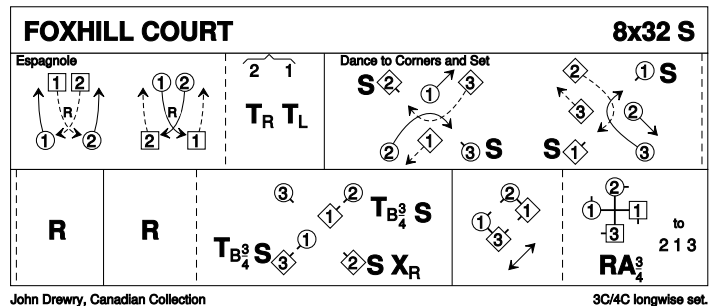

4 THE CHEQUERED COURT J32 · 3/4L

Duncan Brown: RSCDS XLII 3 · Crib: MiniCribbs · Diagram: Keith Rose's Diagrams

- 1-8 1s cross RH, cast 1 place (2s step up), 1s dance 1/2 Figs of 8 (Man round 2s & Lady round 3s) & end facing 1st corners
- 9-16 1s dance Pass+Turn with 1st corners & 1s twirl round in centre to face 4th crnrs, 1s dance Pass+Turn with 4th crnrs & twirl round to BtoB facing own sides
- 17-24 1s dance 6 bars of Double Triangles & end with Petronella turn to 1L between 2s facing 2L & 1M between 3s facing 3M
- 25-32 1s dance reel of 3 across giving RSh to 4th corners (6 bars) & 1s cross RH to own sides

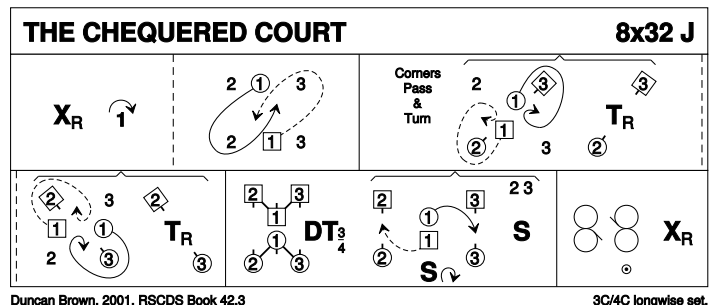

5 RAY MILBOURNE R32 · 4/4L

Derek Haynes: Carnforth Collection of SC Dances 1 · Crib: MiniCribbs · Diagram: Keith Rose's Diagrams

2s & 4s start on opp sides

- 1-8 1s & 4s cross RH, cast in 1 place & dance 1/2 Figs of 8 round end couples
- 9-16 1s+4s dance 1/2 R&L, all dance 1/2 reels of 4 on sides
- 17-24 3s+1s also 4s+2s dance Men's Chain
- 25-32 All circle 8H round & back

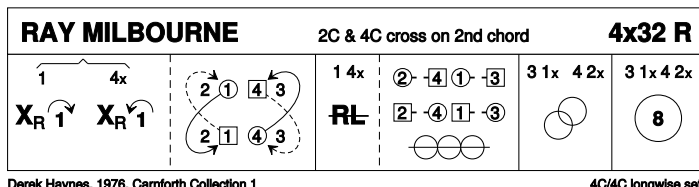

6 THE GENTLEMAN S32 · 3/4L

Roz Scott Huxley: RSCDS XXXV 5 · Crib: MiniCribbs · Diagram: Keith Rose's Diagrams

- 1-8 1s turn 2H & remain in middle facing each other as 2s step up, 1s+2s set (1s advancing & pass LSh to face opposite partner) & dance 1/2 reel of 4 across with 2s with 1s ending reel giving LH to face down on own side between 2s
- 9-16 1s dance down to end between 3s & face each other, 1s+3s set (1s advancing & pass LSh to face opposite partner) & 1/2 reel of 4 across with 3s 1s end giving LH to face up on own side between 3s
- 17-24 1s lead up to top, cross over & cast to 2nd place & 1/2 reels of 3 across (L with 2s & M with 3s)
- 25-32 2s+1s dance Diamond Poussette

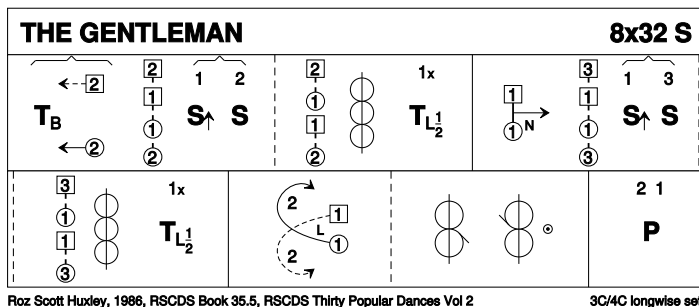

7 WELCOME TO AYR J32 · 3/4L

Jill Hendricksen/Kathy Stewart: RSCDS XLVII 8 · Crib: MiniCribbs · Diagram: Keith Rose's Diagrams

- 1-8 1s+2s dance double Fig of 8 (1s cross down to start)
- 9-16 1s turn 2s on sides (Men RH, Ladies LH) & 1s dance down to turn 3s on sides (Men RH, Ladies LH) & 1s end facing 1st corners
- 17-24 1s dance 1/2 reel of 4 with corners & pass RSh to face 2nd corner, 1s dance 1/2 reel of 4 with crnrs & 1s end in middle LSh to LSh facing own sides
- 25-32 1M+3s (at top) also 1L+2s dance RH across (1s end in 2nd place opposite sides), all chase clockwise 1/2 way to own sides

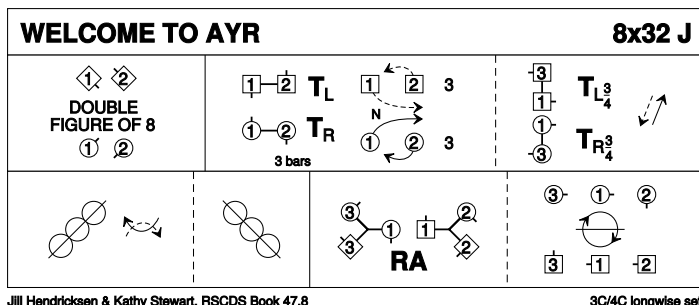

8 THE MONTGOMERIES' RANT R32 · 3/4L

Castle Menzies (18C): RSCDS X 1 · Crib: MiniCribbs · Diagram: Keith Rose's Diagrams

- 1-8 1s cross RH & cast down to 2nd place (2s step up), cross LH & 1L casts up while 1M casts down
- 9-16 1s dance reels of 3 across, 1L with 2s (RSh to 2M) & 1M with 3s (RSh to 3L)
- 17-24 1s NHJ (Lady on Mans left) set to 2L & turn inwards to set to 3M, set to 3L & turn inward & set to 2M. End facing own 2nd corner (1L pull back LSh to face down)
- 25-32 2s+1s+3s dance reels of 3 on opposite sides 1s giving RSh to 2nd corner, 1s cross RH to 2nd place own sides

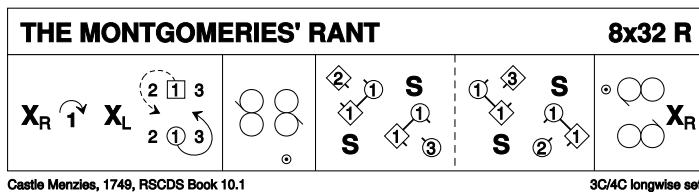

9 GLAYVA J32 · 2/4L

John Drewry: The Canadian Book of Scottish Country Dances · Crib: MiniCribbs · Diagram: Keith Rose's Diagrams

- 1-8 1s+2s dance 1/2 double Fig of 8, 1L+2L & 1M+2M turn on sides (Men LH Ladies RH)
- 9-16 1s+2s dance 1/2 double Fig of 8, 1L+2L & 1M+2M turn on sides (Men RH Ladies LH)
- 17-24 1s+2s dance RH across ending with dancers turning (individually) by the right to places & setting
- 25-32 1s+2s dance Espagnole: 1s+2s cross the set, (Ladies dancing RH joined, between Men), Ladies change places RH, 1s+2s cross back (Men dancing RH joined between Ladies) Men change places RH (1s+2s have now changed pstns), 2s turn RH & 1s turn LH

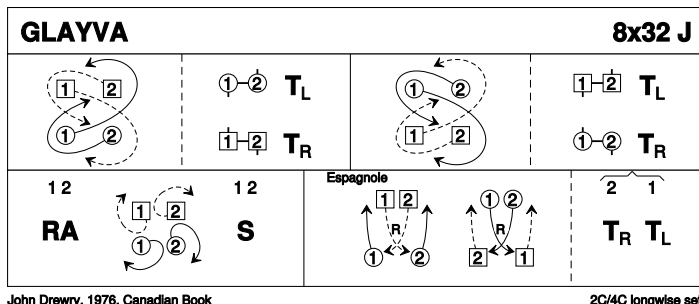

10 THE COUNTESS OF DUNMORE'S REEL R32 · 3/4L

Deirdre MacCuih Bark: RSCDS XLIX 12 · Crib: MiniCrib · Diagram: Keith Rose's Diagrams

- 1-8 1s set, dance down below 3s, cast up to 2nd place & set advancing to face 1st corners (2s step up 3-4)
- 9-16 1s turn 1st corners RH, pass RSh, turn 2nd corners RH, pass RSh to 2nd place own side facing out (corners dance 4 bars)
- 17-24 Promenade (Chaperoned) Chain progression:
 17-18 1M casts up, 1L casts down as 2s+3s turn 3/4 RH into line up/down set
 19-22 1M+2L & 1L+3M, in prom hold dance clockwise to opp end of line as 2M+3L (in middle) turn 1.1/2 LH
 23-24 1s dance clockwise to 2nd place own side as 3s+2s turn partners 3/4 RH to own sides. All face clockwise 3 1 2
- 25-32 3s+1s+2s dance clockwise 1/2 round set. All set, cross RH to own sides. 2 1 3

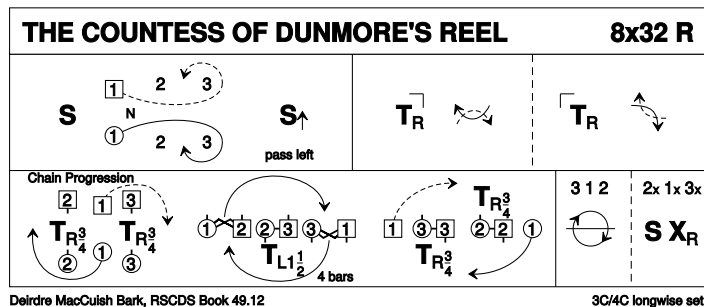

11 MONYMUSK S32 · 3/4L

John Preston (18C): RSCDS XI 2 · Crib: MiniCrib · Diagram: Keith Rose's Diagrams

- 1-8 1s turn RH & cast to 2nd place; turn 1.1/4 times LH (4 bars) to end 1L between 2s facing down, 1M between 3s facing up
- 9-16 2s+1s+3s set twice, 1s Petronella turn on second setting onto opposite sides (bars 11-12) & all set twice again on sides. 2 (1) 3
- 17-24 2s+1s+3s circle 6H round & back
- 25-32 1s dance reels of 3 on sides giving RSh to person on their Right (2nd corner) & 1s cross RH to places. 2 1 3

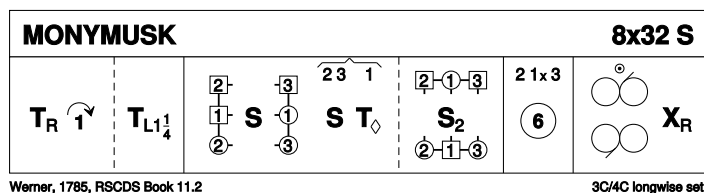

12 MIDNIGHT OIL J48 · 5/5L

John Drewry: Bankhead Book Part 3 · Crib: MiniCrib · Diagram: Keith Rose's Diagrams

- 1-8 1s & 3s lead down & 3/4 turn RH to L facing down & M up, retaining hold of RH set & L turns under ptrns RT arm to dance up (Men follow ptrnr)
- 9-16 1s & 3s dance RH across with 2L/4L, 1s & 3s dance LH across with 4M/5M to end facing 1st corners
- 17-24 1s also 3s dance Pass+Turn with 1st corners & pass RSh to face 2nd corners, dance Pass+Turn with 2nd corners & into centre facing partner (L facing down M up)
- 25-32 1s+3s dance reel of 4 up & down centre of dance & end in centre holding partners nearer hand (1s face Ladies side & 3s face Men's side)
- 33-40 1s also 3s dance out sides & cast, dance in to meet ptrnr (1M & 3L pass LSh) to dance out other side & cast back to middle (1M & 3L pass RSh & face each other)
- 41-48 1L also 3M set twice while 1M+3L turn RH, 1s & 3s turn partner LH & cast down 1 place on own sides. End 2 4 1 5 3

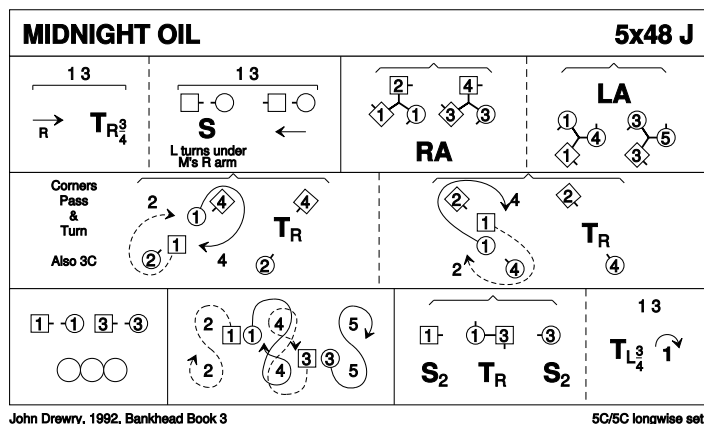

13 THE FALLS OF ROGIE R32 · 3/4L

Jean Attwood: Alexander Dances Book 1 · Crib: MiniCrib · Diagram: Keith Rose's Diagrams

- 1-8 1s cross RH & cast 1 place, 1s cross RH & cast 1 place (Man up, Lady down)
- 9-16 1s dance 1/2 reels of 3 across (1M with 2s & 1L with 3s), set in lines across & change places RH with opposite person
- 17-24 2s+1s+3s chase clockwise 1/2 way, 1s dance in & turn 1.1/4 RH to face 1st corner positions as 2s & 3s continue to chase on to places (as bar 16)
- 25-32 1s dance 1/2 reel of 4 with 1st corners, passing RSh dance 1/2 reel with 2nd corners & cross passing RSh to 2nd place own sides

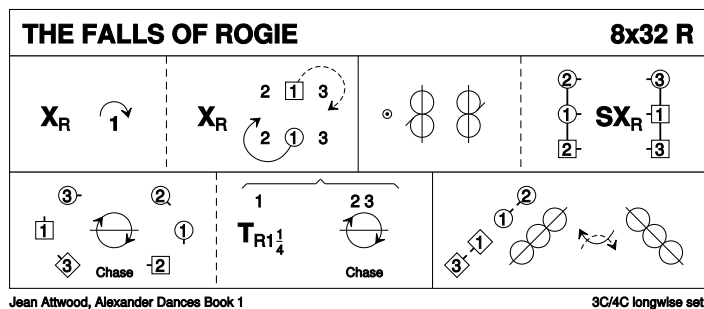

14 THE SALTIRE STRATHSPEY S32 · 4/4L

Barbara Anglin: RSCDS XLV 4 · Crib: MiniCribbs · Diagram: Keith Rose's Diagrams

- 1-8 1M+2L also 3L+4M turn 2H 1.1/2 times to change places, all Men dance LH across & end facing anticlockwise giving RH to partners
- 9-16 All Set+Link with partners & Set+Link again to end on sides (1s+4s Ladies side & 2s+3s Mens side with Ladies on line ends)
- 17-24 All dance RSh reels of 4 on sides
- 25-32 1L+2M also 3M+4L turn 2H 1.1/2 times to (2)(1)(4)(3), end couples (2s & 3s) cross RH **while** centre cpls dance LH across 1/2 way & all set. 2 4 1 3

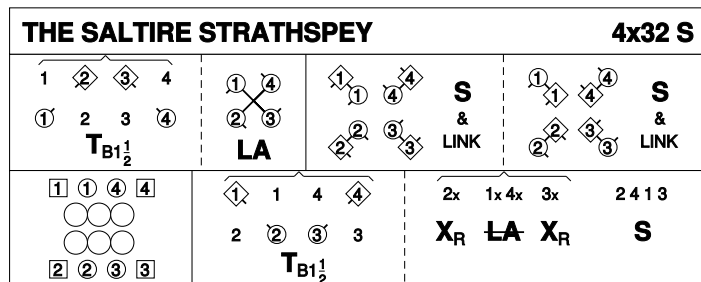

Barbara Anglin, 2001, Gatineau Gathering, RSCDS Book 45.4

4C/4C longwise set.

15 LOCH FITTY JIG J32 · 3/4L

Alison Austin: A Dunfermline Collection · Crib: MiniCribbs · Diagram: Keith Rose's Diagrams

- 1-4 1s set, 1L casts down 1 place (2L steps up).
- 5-8 1L dances 1/2 Fig 8 round 3M **while** 1M sets & casts down 1 place (2M steps up), 1s meet on Men's side.
- 9-12 1s in prom hold dance 1/2 reel of 3 with 3s (pass 3L LSh).
- 13-16 1s divide, 1L dances 1/2 reel with 2s (pass 2M LSh) **while**, 1M continues 1/2 reel with 3s.
- 17-20 1s in prom hold dance 1/2 reel with 2s (pass 2M on Ladies' side RSh)
- 21-24 1s dance out of Men's side, 1M casts up to finish between 2s facing down, 1L casts down to finish between 3s facing up.
- 25-28 All Set+Link for 3. (2) (1) (3)
- 29-32 All turn partner RH 1.1/2 (or birl) to own sides. 2 1 3

Optional variation on 2nd turn, 1M leads i.e., casts first, dances 1/2 Fig 8 round 3L meets partner on Ladies' side. Reels follow same pattern but to opp sides, set and link finishes (2) 1 (3) so 1s turn RH last 4 bars.

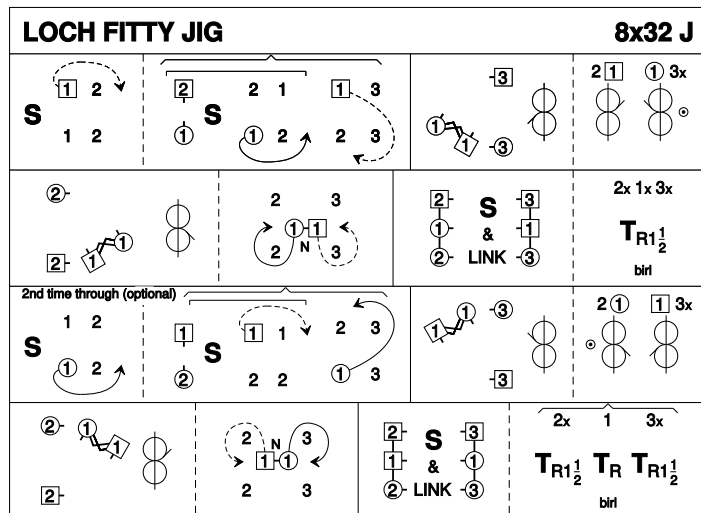

Alison Austin, 2021, A Dunfermline Collection

3C/4C longwise set.

16 THE REEL OF THE ROYAL SCOTS R32 · 3/4L

Roy Goldring: The Leaflet Dances with Music · Crib: MiniCribbs · Diagram: Keith Rose's Diagrams

- 1-4 1s 1/2 turn 2s on sides (1M RH - 1L LH) to 1s in centre BtoB facing out, 2s+1s+3s set,
- 5-8 1s 1/2 turn 3s on sides (1M LH - 1L RH) to 3s in centre BtoB facing out & 2s+3s+1s set
- 9-16 1s followed by 3s dance up between 2s, cast down 1 place; 1s dance down between 3s & cast up to 2nd place, 3s loop into 3rd place
- 17-24 1s turn 1st corners RH, pass partner RSh turn 2nd corners RH & cross passing partner RSh to 2nd place own sides
- 25-32 2s+1s+3s circle 6H round & back

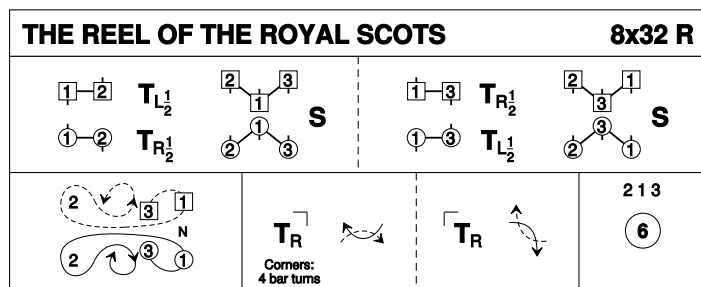

Roy Goldring, 1983, RSCDS Leaflet 7

3C/4C longwise set.