

# 23-05-02 Atholl SCDC - Rachel's Programme

## 1 ST ANDREW'S FAIR J32 · 3/4L

Roy Goldring: Five Scottish Country Dances 1982 · Crib: MiniCribs · Diagram: Keith Rose's Diagrams

- 1-8 1s cross RH, cast 2 places, cross LH below 3s & cast up to 2nd place own sides
- 9-16 2s+1s+3s 1/2 turn RH retain hands & all set (M face down & L up) 2L leads Ladies across & down own side **while** 3M leads Men across & up
- 17-24 3s+1s+2s circle 6H round & back
- 25-32 3s+1s+2s 1/2 turn LH retain hands & all set (M face up & L down) 2L leads Ladies across & up own side **while** 3M leads Men across & down

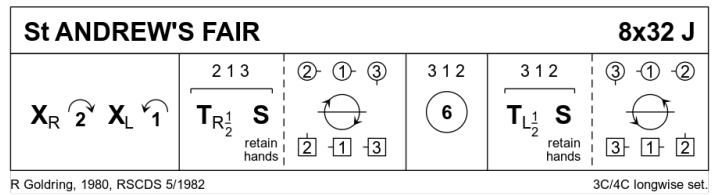

## 2 THE SALMONFIELD POACHER R40 · 3/4L

Ian Barbour: Highlander Collection Vol 1 · Crib: MiniCribs · Diagram: Keith Rose's Diagrams

- 1-8 1s set & cast 1 place, turn LH into double triangle positions facing own sides
- 9-16 2s+1s+3s set, 1s turn to face 1st crnr & dance 1/2 diaig reel of 4 with 1st crnr, 1s turn right about into triangle position Man facing down & Lady up
- 17-24 2s+1s+3s set, 1s turn to face 2nd corners & dance 1/2 reel of 4 with 2nd corners & 1s end 2nd place opposite sides
- 25-32 3s+1s+2s Set+Link for 3 twice
- 33-40 2s+1s+3s circle 6H round 1/2 way & chase back anticlockwise

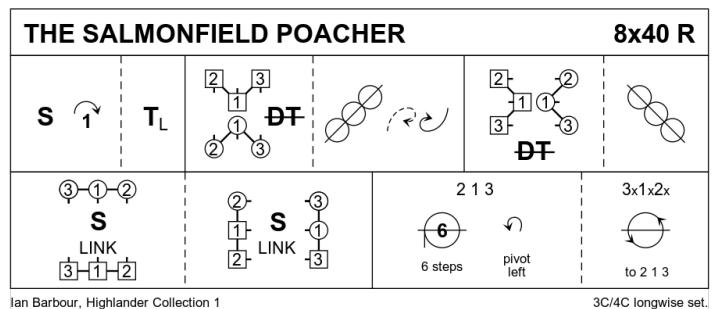

## 3 SANDS OF MORAR S32 · 3/4L

Barry Priddey: RSCDS XLV 6 · Crib: MiniCribs · Diagram: Keith Rose's Diagrams

- 1-8 1s dance Fig of 8 round 2s giving hands when possible
- 9-16 1s dance reflection reels of 3 on own sides (1s dance down between 2s to begin)
- 17-24 1s turn 2H & dance down middle to 3rd pl as 2s+3s continue reel & dance down behind 1s, all set & 1s followed by 2s+3s cast up to orig pls
- 25-32 1s+2s dance the Tourbillon :  
1s & 2s turn partners 2H 1/2 way, 1M & 2L lead partners on 1 place clockwise to end 1s on Ladies side & 2s on Men's side, 1s set to 2s  
1s & 2s 1/2 turn partners 2H, 1L & 2M lead partners on 1 place to end 2s in 1st pl & 1s in 2nd pl & 2s+1s cross RH to own sides. 2 1 3

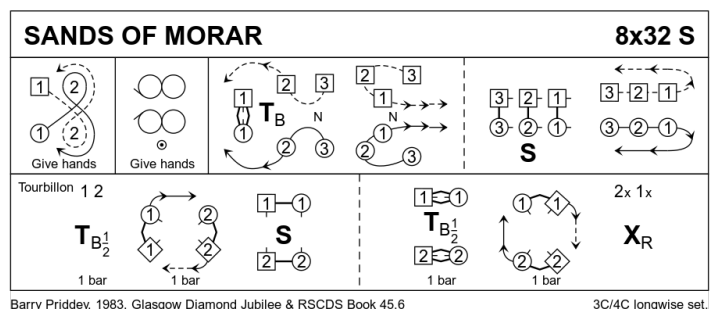

## 4 THE WEATHERCOCK J32 · 4/4L

Veronica Hughes: A Second Book of Graded Scottish Country Dances · Crib: MiniCribs · Diagram: Keith Rose's Diagrams

- 1-8 All dance RSh reels of 4 on own sides
- 9-16 1s & 3s set advancing into centre (give RH to partner) & Bal-in-Line, 1s+2s & 3s+4s dance RH across once round
- 17-24 Centre couple (1L+3M) 3/4 turn LH in centre **while** 1M & 3L dance round crnr to meet ptr in line across & set, repeat & set in line up/down dance
- 25-32 3s+2s & 1s+4s dance RH across once round, turn facing corner RH (2L+3L, 3M+2M, 1L+4L & 1M+4M) onto own sides (Ladies turn 1.1/2 **while** Men turn once round). 2 3 4 1

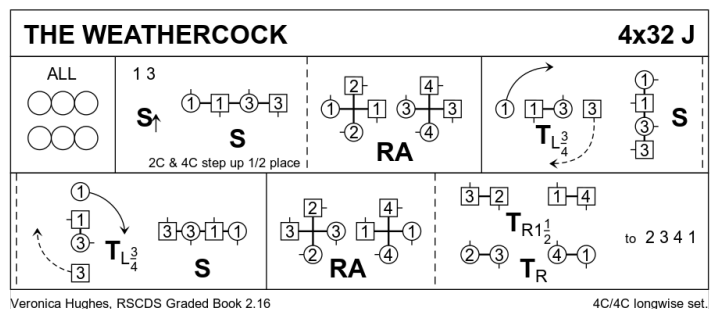

**5 ALTAMONT FAIR R32 · 3/4L**

*Peter Price: Nutmeg Collection of Scottish Country Dances · Crib: MiniCrib*s

- 1-8** 1s set, cast 1 place, set 1L casts up & 1M down
- 9-16** 1s dance reels of 3 across (1L with 2s & 1M with 3s) & 1s end facing 1st corners
- 17-24** 1s set to 1st corners, turn partner RH, set to 2nd corner & turn partner RH to face 1st corners
- 25-32** 1s dance Pass+Turn with 1st corners & pass RSh to face 2nd corners, Pass+Turn with 2nd corners & end passing RSh to 2nd places

**6 S-LOCOMOTION S32 · 4/4L**

*Ken Jones: RSCDS XLI 8 · Crib: MiniCrib*s · Diagram: Keith Rose's Diagrams

- 1-8** 1L+2L cross passing partner LSh & cast down 2 places as 3M+4M cross & cast up 2 places, top 4 Men also bottom 4 Ladies dance LH across.
- 9-16** 1M+2M cross passing opp dancer RSh & cast down 2 places as 3L+4L cross & cast up 2 places, top 2 cpls also bottom 2 cpls dance RH across.
- 17-24** 3s+4s+1s+2s dance 1/2 RSh reels of 4 on sides, 1s+4s+3s (bottom 3 couples) dance 1/2 reels of 3 on sides.
- 25-32** All set, cross RH, 2s+3s also 4s+1s circle 4H round to left.

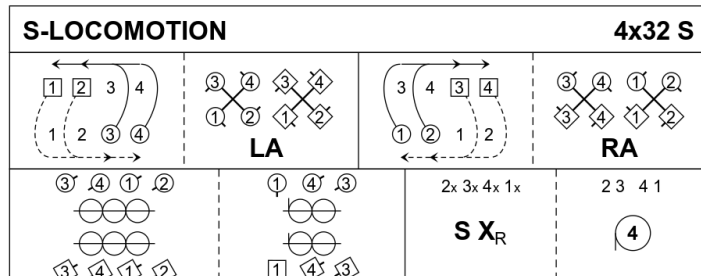

Ken Jones, 1998, RSCDS Book 41.8

4C/4C longwise set.

**7 THE WILD GEESSE J32 · 3/4L**

*RSCDS XXIV 3 · Crib: MiniCrib*s · Diagram: Keith Rose's Diagrams

- 1-8** 1s+3s set advancing & Bal-in-Line (Man above Lady), turn partners RH & 1s cast to 3rd place **while** 3s lead up to 1st place
- 9-16** 3s+1s set advancing & Bal-in-Line (Man above Lady), turn partners RH & 3s cast to 3rd place **while** 1s lead up to 1st place
- 17-24** 1s lead down & back to 2nd place
- 25-32** 2s+1s dance R&L

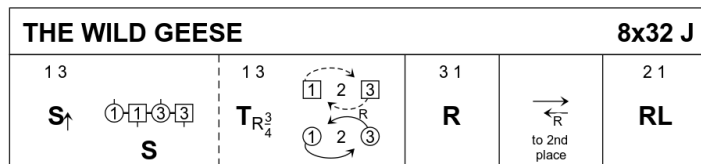

RSCDS Book 24.3

3C/4C longwise set.

**8 POLHARROW BURN R32 · 5/5L**

*Hugh Foss: Magazine Dances 2005-2009 · Crib: MiniCrib*s · Diagram: Keith Rose's Diagrams

- 1-8** 1s & 3s cross RH, cast 1 place (2s & 4s step up) & dance 1/2 Fig of 8 round couple above them
- 9-16** 1s & 3s turn RH then turn LH (long turns) to face 1st corners **while** 2s & 5s change places RH & chase clockwise to other end of set
- 17-24** 1s & 3s dance 1/2 diag reels of 4 with 1st corners, pass partner LSh, dance 1/2 diag reels of 4 with 2nd corners
- 25-32** 1s & 3s dance 1/2 diag reels of 4 with 3rd corner, turn partner LH & cast down 1 place own sides. 2 4 1 5 3

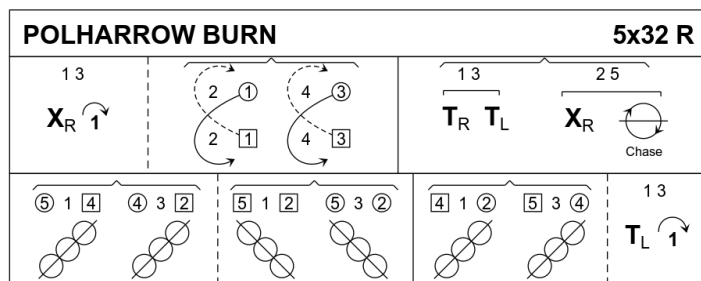

Hugh Foss, 1967, Glendarroch S D Sheets, www.dancearchives.co.uk

5C/5C longwise set.

**PROGRAMME ITEM – Interval**

**9 QUARRIES' JIG J32 · 3/4L**

*Kent W Smith: RSCDS XXXVI 3 · Crib: MiniCrib*s · Diagram: Keith Rose's Diagrams

- 1-8** 1s set, cast 1 place & dance round 1st corners passing corners LSh
- 9-16** 1s dance reels of 3 across (1st Man with 2s & 1st Lady with 3s), 1s turn LH to face 1st corners
- 17-18** Centre dancers change with 1st corners RH **while** 2nd corners set
- 19-20** 1st corners (in centre) change places LH **while** new 1st & 2nd corners dance clockwise round to next corner place
- 21-24** Repeat the Fig in bars 17-20 from new places
- 25-32** Repeat 17-20 from new places, 1s end by turning LH to 2nd place on opposite sides, 2s+1s+3s set on sides & 1s cross back RH

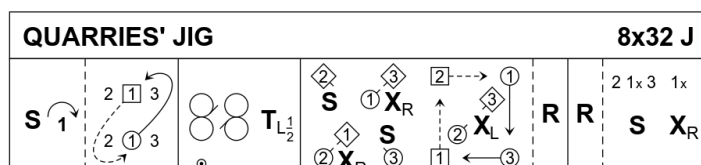

Kent W Smith, RSCDS Book 36.3

3C/4C longwise set.

## 10 BLOOMS OF BON ACCORD R32 · 4/4L

John Drewry: *Deeside Book Part 2* · Crib: *MiniCribs* · Diagram: *Keith Rose's Diagrams*

3s & 4s on opp sides

- 1-8 All set & 1s+2s also 3s+4s dance RH across once round, 1s & 4s cast in 1 place to 2 1 (4)(3)
- 9-12 1s & 4s cross RH & cast to ends of set to meet partners in prom hold & dance into centre of dance
- 13-16 1s+4s dance round passing RSh & to end 1s in the middle on Men's side facing up & 4s in the middle on Ladies' side facing down
- 17-24 All (1s & 4s in prom hold) dance RSh reels of 3 on sides
- 25-28 4s+1s dance RH across in centre once round to end 4s facing up & 1s facing down
- 29-32 4s & 1s lead out of ends crossing & cast in 1 place to end 2 4 (1) (3)

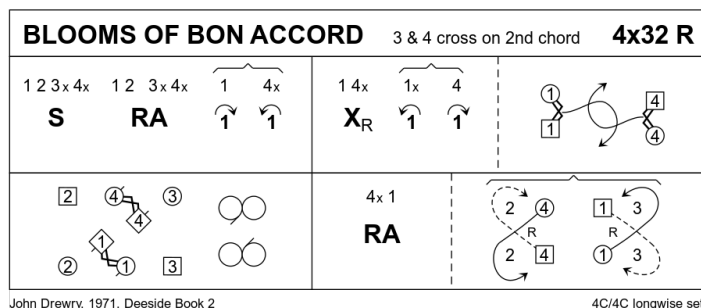

## 11 THE SILVER TASSIE S32 · 3/4L

John Drewry: *The Leaflet Dances with Music* · Crib: *MiniCribs* · Diagram: *Keith Rose's Diagrams*

- 1-8 1s+2s+3s cross RH & set, cross back RH & set
- 9-16 1s & 3s dance double Fig of 8 round 2s (3s casting)
- 17-24 1s followed by 2s+3s dance down, 1s followed by 2s+3s (who part to let 1s thru) dance back to top
- 25-32 1s+2s dance the Rondel

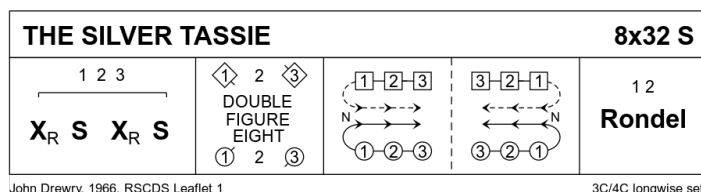

## 12 NETHY BRIDGE J32 · 4/4L

Rachel Wignall: *New Scotland 60th Anniversary Dance Book (1947-2007)* · Crib: *SCDDB Contributed Cribs & Diagrams*

3c+4c cross on 2nd chord (1,2,3x,4x)

- 1- 1c in promhold (1M on the R) Reel3 with 2c (Rsh to 2M) **while** 4c in promhold (4M on the R) Reel3 with 3c (Rsh to 3M), on bar 8 1c+4c dance towards each other and pivot to put W on the R (promhold)
- 9- 2W+1c+4c+3W 1/2 Reel4, on bar 12 1c+4c pivot to put M on the R (promhold) ; 2M+1c+4c+3M 1/2 Reel4, on bar 16 1c+4c pivot to put W on the R
- 17- Repeat bars 9-16 with next cnrs cclw but omit pivot on last bar
- 25- 1c+4c 1/2 RHA, 2c+4c+1c+3c set, turn RH, 2c+3c retaining hands in promhold ready to start reels (W on left of P)

## 13 J. B. MILNE R32 · 3/4L

Hugh Foss: *Thirty Popular Dances, Volume Two* · Crib: *MiniCribs* · Diagram: *Keith Rose's Diagrams*

- 1-8 1M+2L set advancing & turn RH, 1L+2M set advancing & turn RH
- 9-16 1s set advancing to each other & turn 2H, cast to 2nd place & Petronella turn to Lady between 2s & Man between 3s
- 17-24 1s set & 3/4 turn RH **while** 2s+3s change places RH on sides & set, 1s repeat but 2s & 3s cross RH & set
- 25-32 1s set & change places RH **while** 2s+3s change places RH on sides & set, 1s cast round corner to 2nd pl own sides as 2s+3s cross RH & all set

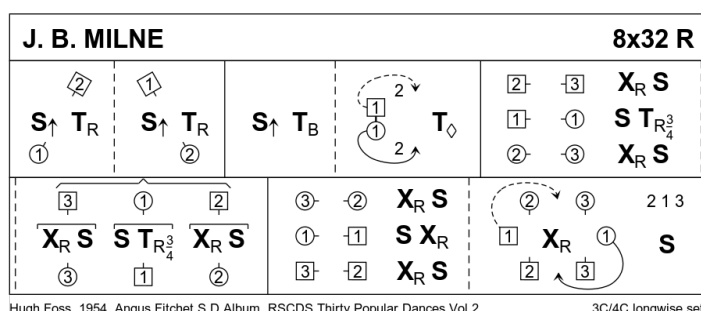

**14 AUTUMN IN APPIN** S32 · 4/4L

John Drewry: RSCDS XXXI 5 · Crib: MiniCribs · Diagram: Keith Rose's Diagrams

3s & 4s start on opp. sides

- 1-8** 2s+3s Petronella turn into centre & set to partner (Men BtoB), 2s+3s 3/4 turn partner RH & dance RH across 1/2 way to change places & end with other partner in prom hold (2M+3L facing Men's side & 3M+2L facing Ladies' side)
- 9-10** 1s & 4s Petronella turn into centre **while** 2M+3L dance out & up on Men's side & 3M+2L dance out & down on Ladies' side
- 11-12** 1s & 4s set to partner **while** 2M+3L/3M+2L cross to other side passing between 'gates' (1s & 4s)
- 13-14** 1s & 4s 1/2 turn RH into prom hold (1s facing Ladies' side & 4s facing Men's side) **while** 2M+3L/3M+2L dance down/up sides
- 15-16** All Promenade cl'wise 1 pl to end in square set (1s on Ladies' side facing 4s on Men's side, 2M+3L in 4th pl face up as 3M+2L in 1st pl face down)
- 17-24** 1s+4s dance 1/2 Ladies' Chain (across) , 2s+3s dance 1/2 Men's Chain (up/down). 2s & 3s end with Lady on Man's left
- 25-32** All set in square set & circle 8H round to left, dance into centre, turn right & spiral out to own side lines ending 2 4 (1) (3)

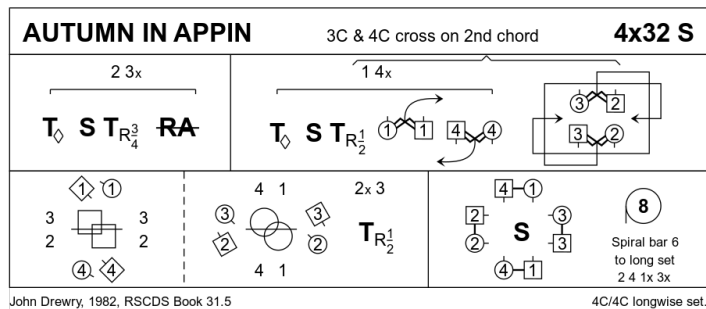

John Drewry, 1982, RSCDS Book 31.5

4C/4C longwise set.

**15 MUIRLAND WILLIE** J32 · 3/4L

RSCDS XXI 9 · Crib: MiniCribs · Diagram: Keith Rose's Diagrams

- 1-4** 1s lead down middle & cross over to cast up to 2nd pl **while** 2s set & cross RH to 3rd pl **while** 3s cast up to 1st place & cross RH
- 5-8** All set & 1/2 turn 2H to own side
- 9-16** Repeat bars 1- 8 from new pstns
- 17-24** 1s lead up to 1st place (4 bars); 1s set (2 bars) then 1s+2s set advancing ready for ...
- 25-32** 1s+2s dance Poussette. 2 1 3

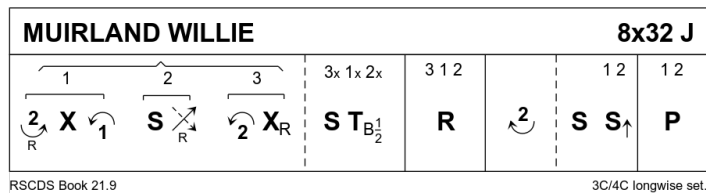

RSCDS Book 21.9

3C/4C longwise set.

**16 THE IRISH ROVER** R32 · 3/4L

James B Cosh: Twenty Two SCD · Crib: MiniCribs · Diagram: Keith Rose's Diagrams

- 1-8** 1s dance down below 3s & cast up to 2nd place own sides, 1L dances RH across with 2s **while** 1M dances RH across with 3s
- 9-16** 1s dance 1/2 diagonal reel of 4 with 1st corners, 1/2 reel with 2nd corners & 1/2 turn LH in centre to face 1st corners
- 17-24** 1s dance reels of 3 across giving LSh to 1st corners ending in 2nd place own sides
- 25-32** 1s dance Diag R&L (1M crossing down & 1L crossing up to start)

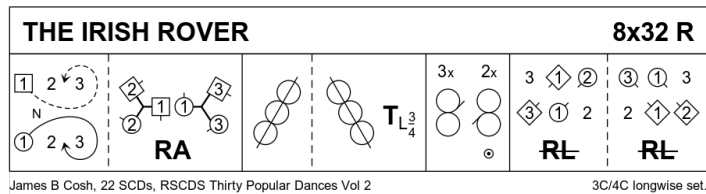

James B Cosh, 22 SCDs, RSCDS Thirty Popular Dances Vol 2

3C/4C longwise set.