

Atholl SCDS 10 Oct 23 - Bill's Programme

1 AUCHINELLAN JIG J32 · 3/4L

Alice McLean: *The Auchinellan Collection* · Crib: *MiniCrib*s · Diagram: *Keith Rose's Diagrams*

- 1-8 1s+2s set, dance RH across once round, 1s cast to 2nd place as 2s dance up
- 9-16 1s dance reflection reel of 3 on own sides (down between 3s to start)
- 17-24 1s dance 1/2 Figs of 8 (1M up with 2s & 1L down with 3s), 2s+1s+3s chase clockwise 1/2 way
- 25-32 1s dance diag R&L (1M crossing down & 1L crossing up to start)

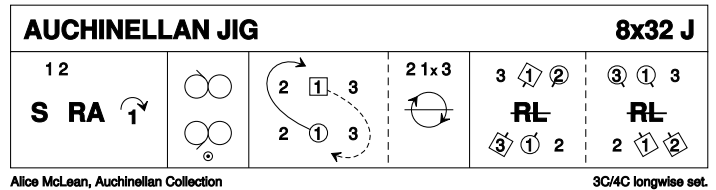

2 GENERAL STUART'S REEL R32 · 3/4L

Castle Menzies (18C): *RSCDS X 3* · Crib: *MiniCrib*s · Diagram: *Keith Rose's Diagrams*

- 1-8 1M sets to 2L & casts 1 place, 1L sets to 2M & casts 1 place
- 9-16 1s turn 1st corner RH & pass partner RSh, turn 2nd corner LH pass partner RSh to face 1st corners
- 17-24 1s dance 'Hello-Goodbye' setting & end BtoB (1M facing up & 1L facing down)
- 25-32 1s give RSh to 2nd corner & dance reels of 3 on sides with 2s+3s & cross RH to 2nd place on own sides

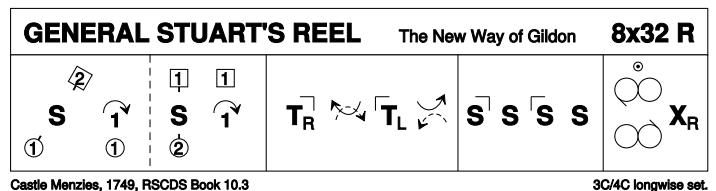

3 FOXHILL COURT S32 · 3/4L

John Drewry: *The Canadian Book of Scottish Country Dances* · Crib: *MiniCribs* · Diagram: *Keith Rose's Diagrams*

1-8 1s+2s dance Espagnole:
1-2 1s+2s cross (Ladies lead across RH passing between Men) with Ladies changing places RH

3-4 1s+2s cross back (Men lead across RH between Ladies) with Men changing places RH

5-8 2s turn RH as 1s turn LH to face 1st corners

9-20 Dance to Corners & Set: (12 bars)

Couple in middle change places with corners passing RSh, corners pass RSh in middle with a 1/4 turn to right to face next corner **while** supporting corners set (2 bars). Repeat 5 more times to end with corners in diagonally opposite place and 1s meet again in middle & pass RSh to face 3rd corner positions

21-24 1s turn 3rd corners 2H to face diagonally in (corners on 1s right) & set **while** 2nd corners set & cross RH

25-32 1s+3rd corners Adv+Ret & dance 3/4 RH across to end 2 1 3

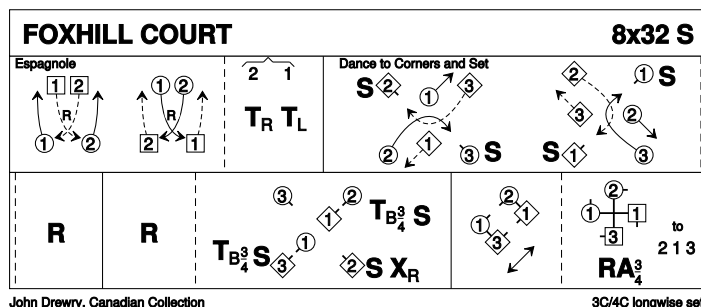

4 THE KELLOHOLM JIG J32 · 3/4L

Peter Hyssett: *The Leaflet Dances with Music* · Crib: *MiniCribs* · Diagram: *Keith Rose's Diagrams*

1-8 1s set & cast 1 place, set on side lines to 1st corners & change places with them RH

9-16 1L+3L also 2M+1M set to each other on sides & change places LH, 1s turn RH 1.1/2 times to 2nd place on own sides

17-24 1s set on side lines to 2nd corners & change places with them RH, 1M+3M also 2L+1L set to each other on sides & change places LH

25-32 3s+1s+2s Adv+Ret, circle 6H round 1/2 way to left

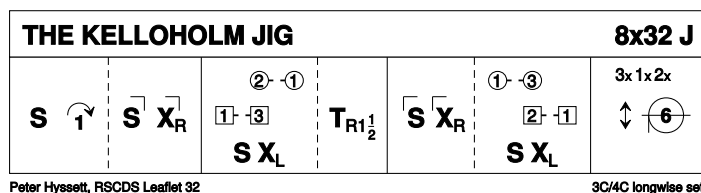

5 PORTNACRAIG R32 · 3/4L

Linda C Gaul: *RSCDS XXXVI 1* · Crib: *MiniCribs* · Diagram: *Keith Rose's Diagrams*

1-8 1s set & 1/2 turn 2H to face 2s, set & 1/2 turn 2s (1M+2L turn RH, 1L+2M turn LH) to end in 2nd place on opposite sides. 2 (1) 3

9-16 2s+1s+3s Adv+Ret 2 steps & circle 6H round 1/2 way to left. (3) 1 (2)

17-24 1s pass LSh, dance 1/2 RSh reels of 4 with 1st corners; pass LSh, dance 1/2 RSh reel of 4 with 2nd corners, end in 2nd place opp sides. 2 (1) 3

25-32 1s dance 1/2 Fig of 8 round 3s & 2s+1s+3s turn RH

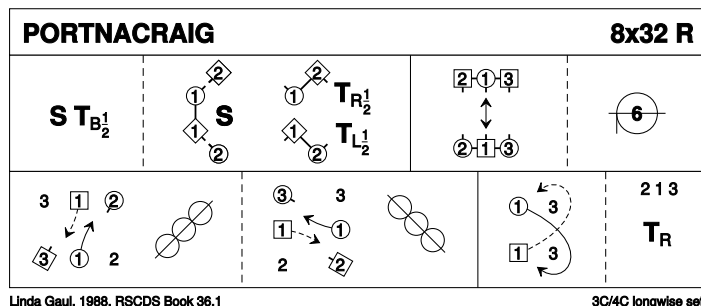

6 THE WINDING ROAD S32 · 4/4L

James B Cosh: *Twenty Two SCD* · Crib: *MiniCrib*s · Diagram: *Keith Rose's Diagrams*

- 1-8 1M+2L & 3M+4L passing RSh dance diagonal reel of 4
- 9-16 2M+1L & 4M+3L passing RSh dance diagonal reel of 4
- 17-24 1s+4s turn RH & cast in 1 place, 1s+4s circle 4H round to left
- 25-32 2s in top place stand **while** 1s+4s+3s dance 1/2 reel of 3 on sides (1s RSh to 4s), 2s+3s & 4s+1s circle 4H round to left

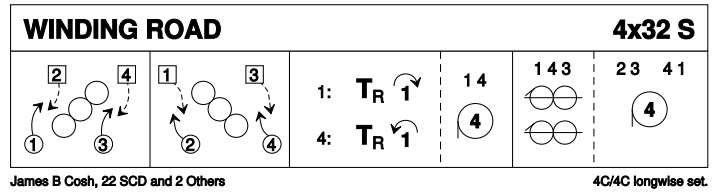

7 THE SHIP IN FULL SAIL J32 · 5/5L

Bill Forbes: *Craigievar Book 2* · Crib: *MiniCrib*s · Diagram: *Keith Rose's Diagrams*

- 1-2 1s & 3s cross down 1 place RH (1M/3M face down to next Lady & 1L/3L face up to Man above **while** 2L faces 5M)
- 3-6 All set, 2L/5M stand as others 3/4 turn RH to lines across (1L b'tw'n 2s face down, 3M b'tw'n 5s face up, 1M+3L b'tw'n 4s)
- 7-8 Top & bottom lines set as centre 4 Bal-in-Line
- 9-16 1s & 3s turn to right & dance reels across (reels of 3 at ends & reel of 4 in middle), 1s & 3s end facing their 2nd corners (LSh to LSh)
- 17-24 1s & 3s set to 2nd corner & turn inwards to face partners 2nd crnr & set, rotate clockwise to face ptrns 1st crnr & set & turn about to set to own 1st crnr
- 25-32 All dance RH across (1L with 2s, 1M+3L with 4s & 3M with 5s), 1s & 3s turn partners LH & cast down 1 place

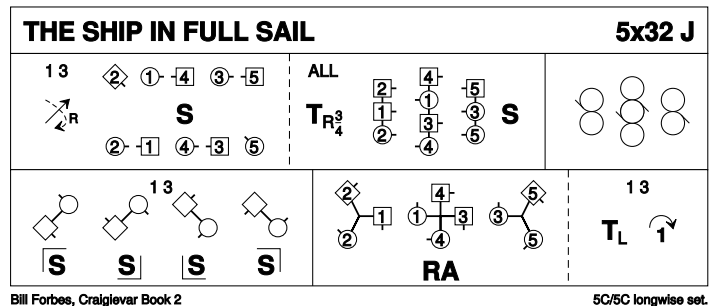

8 THE MONTGOMERIES' RANT R32 · 3/4L

Castle Menzies (18C): *RSCDS X 1* · Crib: *MiniCrib*s · Diagram: *Keith Rose's Diagrams*

- 1-8 1s cross RH & cast down to 2nd place (2s step up), cross LH & 1L casts up **while** 1M casts down
- 9-16 1s dance reels of 3 across, 1L with 2s (RSh to 2M) & 1M with 3s (RSh to 3L)
- 17-24 1s NHJ (Lady on Mans left) set to 2L & turn inwards to set to 3M, set to 3L & turn inward & set to 2M. End facing own 2nd corner (1L pull back LSh to face down)
- 25-32 2s+1s+3s dance reels of 3 on opposite sides 1s giving RSh to 2nd corner, 1s cross RH to 2nd place own sides

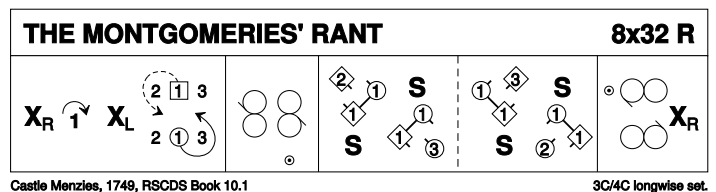

9 THE BACK O' BENNACHIE R32 · 2/4L

John M Duthie: *Eight Scottish Country Dances* · Crib: *MiniCrib*s · Diagram: *Keith Rose's Diagrams*

- 1-8 2M dances reel of 3 with 1s (RSh to 1L)
 9-16 2L dances reel of 3 with 1s (LSh to 1M)
 17-24 1L+2M change places RH, 1M+2L change places RH, 1s+2s dance 1/2 R&L
 25-32 1s cross, cast & dance 1/2 Fig of 8 round 2s

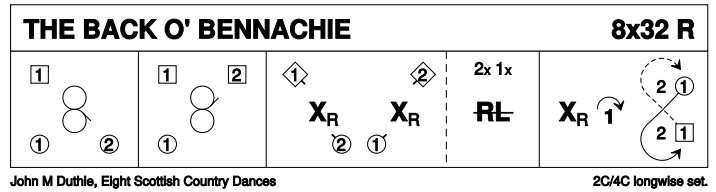

10 THE GLOBE INN J32 · 3/4L

Jackie Johnstone: *Loreburn Dances Book Four* · Crib: *MiniCrib*s · Diagram: *Keith Rose's Diagrams*

- 1-4 1s & 3s 3/4 turn RH & set to partner
 5-16 1s+2s+3s Dance to each 'Corner' & Set (diamond shaped square with corners on sides & ends):
 2s set **while** 1s & 3s change places with partners passing RSh & 1L+3M pass RSh face side 'corners',
 1M & 3L set **while** 1L+2M also 3M+2L change places passing RSh & 2s pass RSh to face end 'corners',
 1L & 3M set **while** 1M+2L also 2M+3L change places passing RSh & 1L+3M pass RSh to face side corners (partners),
 1s & 3s change places with partners passing RSh & 1L+3M pass RSh to face end 'corners',
 1M & 3L set on sides **while** 2L+3M also 1L+2M change places passing RSh & 2s pass RSh to face side 'corners',
 2L+1M also 2M+3L change places passing RSh & 1M+3L pass RSh to face partners (2s in places opposite sides & 3s+1s in centre)
 17-24 1s+3s dance 1/2 reel of 4 up/down centre, 1s+2s+3s set & turn partners LH to end 1s+2s in centre for Poussette & 3s in own places
 25-32 1s+2s dance Poussette. 2 1 3

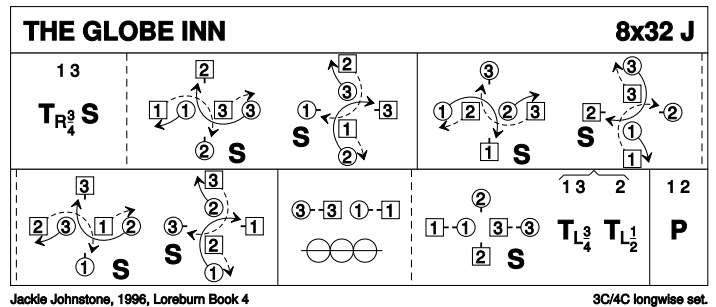

11 MRS MILNE OF KINNEFF S32 · 4S

Alan Macpherson: *The Leaflet Dances with Music* · Crib: *MiniCribs* · Diagram: *Keith Rose's Diagrams*

- 1-8 1s & 3s join hands with partner & adv for 2 steps, turn opposite partner RH once round, retaining opp ptrn hand dance RH across with 2s/4s
- 9-16 Dancing couples (1M+3L & 1L+3M) facing side couples dance parallel reels of 4 across the dance
- 17-18 Dancing couples (1M+3L & 1L+3M) set to side couples
- 19-22 Dancing couples (1M+3L & 1L+3M) dance out between side couples & cast to original places **while** side couples separate & dance into centre to meet partners then holding nearer hands dance out to original places
- 23-24 All turn partners 2H
- 25-32 All circle 8H 1/2 way round to left, 3/4 turn partners RH into prom hold (Ladies on inside) & all Promenade 1 place clockwise

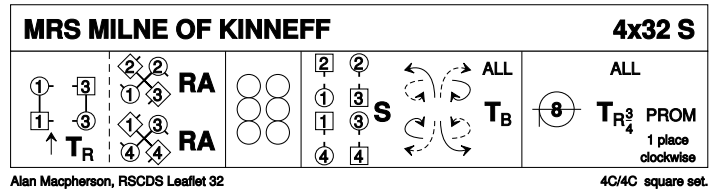

12 INVERNEILL HOUSE R32 · 3/4L

John Drewry: *RSCDS XXXV 2* · Crib: *MiniCribs* · Diagram: *Keith Rose's Diagrams*

- 1-8 1s+2s dance 1/2 double Fig of 8 (1s cross down), 1s dance down between 3s as 2s dance out & up then 1s cast up to 2nd place opp sides
- 9-16 1s+3s dance 1/2 double Fig of 8 (1s cross down), 1s dance up between 2s & cast to 2nd place own sides
- 17-24 1s Petronella to opposite sides
- 25-32 2s & 3s Petronella to own sides **while** 1s cast RSh round 1st corner & cross between 2s/3s, 1s cast to 2nd place own sides & all set

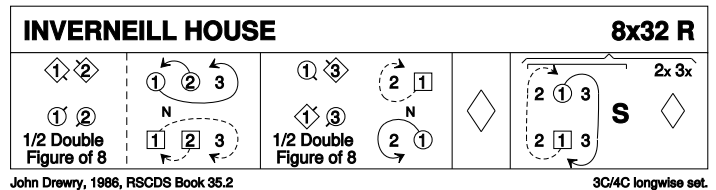

13 RODNEY'S RANT J32 · 3/4L

Ann Dix: *QE Diamond Jubilee Dances* · Crib: *MiniCribs* · Diagram: *Keith Rose's Diagrams*

- 1-8 1s set & cast 1 place; 1s dance down between 3s & cast up to 2nd places
- 9-16 1s dance Diag R&L. (3)1(2)
- 17-24 All Set+Link for 3 twice. 2(1)3
- 25-32 1L dances 1/2 Fig of 8 round 2s as 1M dances 1/2 Fig of 8 round 3s (1L up, 1M down); all turn partners RH

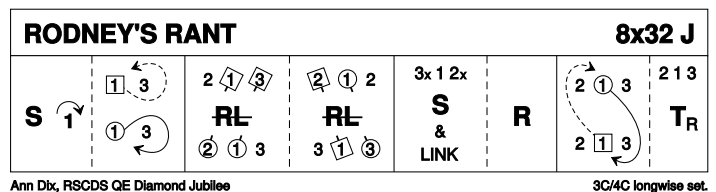

14 THE MORAY RANT S48 · 3/3L

John Drewry: Silver City Book of SCD · Crib: MiniCribs · Diagram: Keith Rose's Diagrams

- 1-8** 1s dance Inveran Reels with 2s+3s & 1s cross RH to opposite sides
- 9-16** 1s set advancing & turn 2H, dance down & out between 2s & 3s then cast down behind 3s to turn in to face 3s
- 17-24** 1s set & turn 3s (1s dancing out between 2s & 3s), dance up between 3s & out between 2s+3s then cast up behind 2s to turn in to face 2s
- 25-32** 1s set & turn 2s (1s dancing out between 2s & 3s) into 1st place opp sides, 1s dance 1/2 Fig of 8 round 2s back to 1st place own sides
- 33-40** 1s+2s circle 4H once round to Left, 1s facing 2s set & 1s cast to 2nd place as 2s lead up to 1st place
- 41-48** 1s+3s circle 4H once round to Left, 1s facing 3s set & 1s cast to 3rd place as 3s lead up to 2nd place

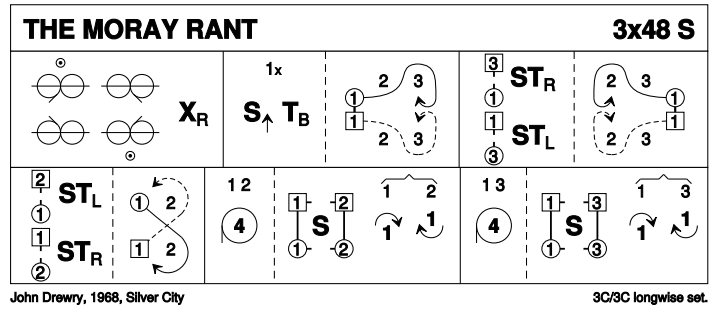

15 THE ROSELATH CROSS J32 · 3/4L

Henrietta Vosper: RSCDS XLI 10 · Crib: MiniCribs · Diagram: Keith Rose's Diagrams

- 1-8** 1s+2s+3s dance reflection reels of 3 on sides (1s dance in & down to start) & end with 1s in 2nd pl BtoB facing own sides & 2s in 1st pl
- 9-16** 2s+1s+3s set, 1s 1/4 turn to right & set with 2s+3s (as Crown Triangles), 1s dance RSh round RH crnr into middle BtoB facing opp sides
- 17-24** Repeat from new positions 1s ending in 2nd place own sides
- 25-32** 1s dance reels of 3 across (Lady with 2s & Man with 3s)

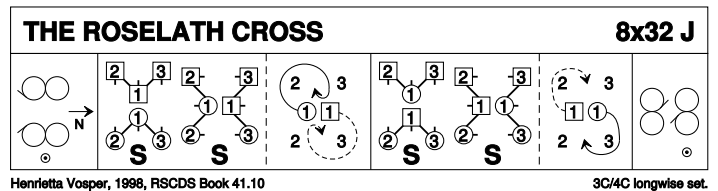

16 TAMBOURINE R32 · 3/4L

Lawrie Bowlen: East Ivanhoe Book · Crib: MiniCribs · Diagram: Keith Rose's Diagrams

- 1-8** 1s lead down the middle & back to 2nd place own side (2s step up 3-4)
- 9-16** 1s dance 1/2 LSh reels of 3 across, passing 1st corners LSh;
- 1s dance 1/2 RSh reels of 3 on opposite sides (Man up, Lady down). 1s end in 2nd place opp sides, all dancing loops into place
- 17-24** 1s dance 1/2 LSh reels of 3 across (Man up Lady down);
- 1s dance 1/2 RSh reels of 3 on own sides (Man down, Lady up). End 2 1 3 4
- 25-32** 2s+1s+3s circle 6H round & back

