

# 2023-01-31 Atholl SCDC Programme by Claire and Brian East

## 1 SHIFTIN' BOBBINS R32 · 3/4L

Roy Clowes: *Thirty Popular Dances, Volume Two* · Crib: *MiniCribbs* · Diagram: *Keith Rose's Diagrams*

- 1-8 1s cross RH to double triangle position with 2s+3s & set, 1s cast up to top & dance down until they are between 2s & 3s
- 9-16 1L dances RH across with 2M+3M **while** 1M dances LH across with 2L+3L, 1s followed by 2s+3s dance down centre
- 17-24 3s followed by 2s+1s dance up & 3s+2s cast down to places, 1L dances LH across with 2M+3M **while** 1M dances RH across with 2L+3L
- 25-32 1s dance up to top & cast down to 2nd place opposite side, 1s dance 1/2 Fig of 8 around 2s to end in 2nd place on own sides

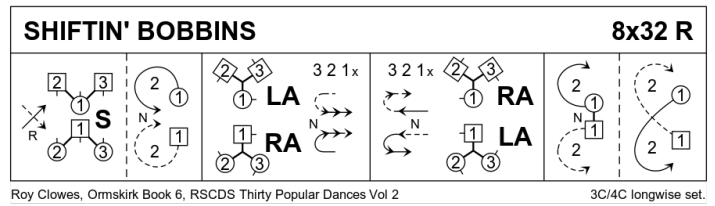

## 2 WELCOME TO AYR J32 · 3/4L

Jill Hendricksen/Kathy Stewart: *RSCDS XLVII 8* · Crib: *MiniCribbs* · Diagram: *Keith Rose's Diagrams*

- 1-8 1s+2s dance double Fig of 8 (1s cross down to start)
- 9-16 1s turn 2s on sides (Men RH, Ladies LH) & 1s dance down to turn 3s on sides (Men RH, Ladies LH) & 1s end facing 1st corners
- 17-24 1s dance 1/2 reel of 4 with corners & pass RSh to face 2nd corner, 1s dance 1/2 reel of 4 with crnrs & 1s end in middle LSh to LSh facing own sides
- 25-32 1M+3s (at top) also 1L+2s dance RH across (1s end in 2nd place opposite sides), all chase clockwise 1/2 way to own sides

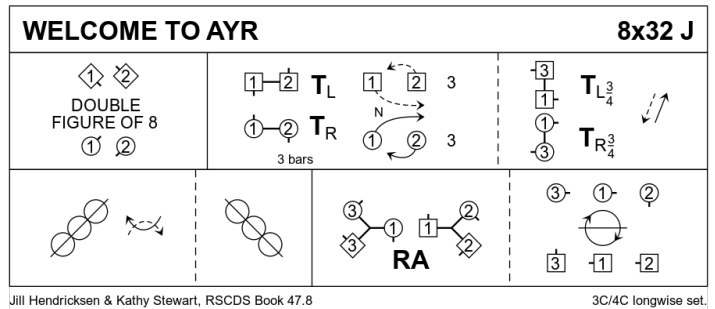

## 3 SAINT COLUMBA'S STRATHSPEY S32 · 5/5L

Vicky Sproule & Sadie L. Gillan: *Saint Columba's Strathspey (Leaflet)* · Crib: *MiniCribbs* · Diagram: *Keith Rose's Diagrams*

- 1-8 2s+4s dance RH across, 2s dance up **while** 4s dance down, 2s & 4s casting round ends on own sides to face 1st corners
- 9-16 2s+4s Pass+Turn with 1st corners, pass partner LSh & Pass+Turn with 2nd corners & into centre facing partner (L facing down M up)
- 17-24 2s+4s dance reel of 4 ending in original places on sides
- 25-32 2s & 4s set & cast down 1 place **while** 3s & 5s set & dance up 1 place, 1s & 2s turn RH & cast down 1 place. 3 1 5 2 4

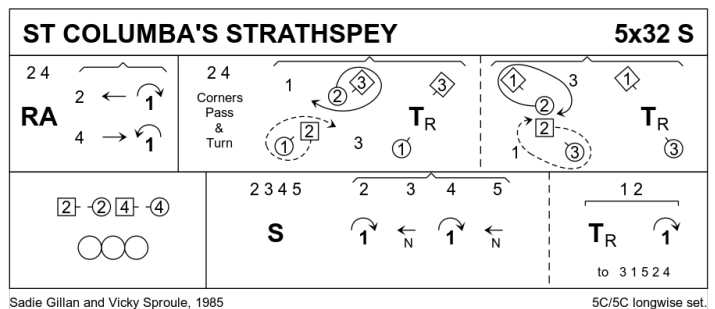

## 4 THE HAZEL TREE J32 · 3/4L

John Drewry: *The Brodie Book* · Crib: *MiniCribbs* · Diagram: *Keith Rose's Diagrams*

- 1-8 1s+2s dance Espagnole:
  - 1-2 1s+2s cross (Ladies lead across RH passing between Men) with Ladies changing places RH
  - 3-4 1s+2s cross back (Men lead across RH between Ladies) with Men changing places RH
  - 5-8 2s turn RH as 1s turn LH to face 1st corners
- 9-16 1s turn 1st corners RH, pass RSh, turn 3rd corner LH & pass LSh to face 2nd corner
- 17-24 1s turn 2nd corners RH, pass RSh, turn 4th corner LH, 1s pass LSh to face down in middle (opposite sides) left hands joined
- 25-32 1s lead down below 3s, cross, cast up to 2nd place own sides, 2s+1s+3s turn RH

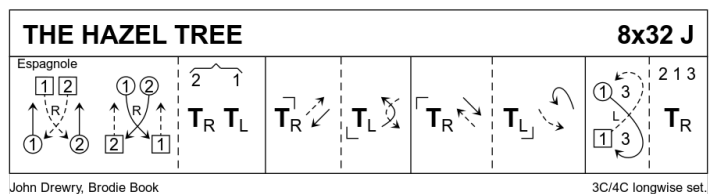

**5 REEL OF THE PUFFINS R32 · 4/4L**

John Bowie Dickson: Dunedin Dances Book 5 · Crib: MiniCribs · Diagram: Keith Rose's Diagrams

3s & 4s start on opp sides

- 1-8** 1s & 4s cross RH & cast in 1 place to join hands to form a circle, set twice turning right about to face nearest corner
- 9-16** 2s & 3s dance full diagonal RSh reels of 4 giving LH in centre **while** 1s & 4s dance 1/2 diagonal RSh reel & pass LSh in centre to face next corner anticlockwise; dance 1/2 RSh reel with that corner & pass LSh in centre to face next corner anticlockwise
- 17-24** 4s & 1s turn corners RH & dance LH across 1/2 way, turn diagonally opposite corners RH & 1s+4s change places LH on the sides
- 25-32** All dance RSh reels of 4 on sides. 2 4 (1)(3)

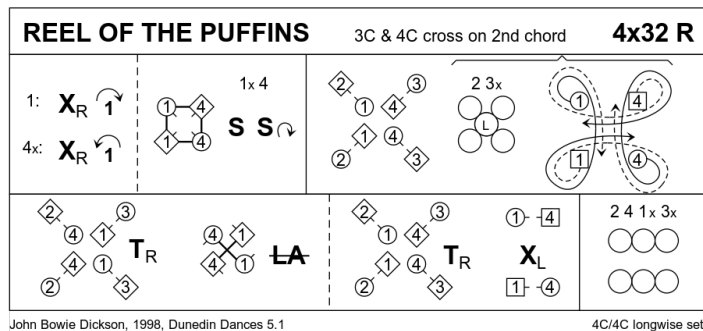

**6 THE DUCHESS TREE S32 · 3/4L**

John Drewry: The Brodie Book · Crib: MiniCribs · Diagram: Keith Rose's Diagrams

- 1-8** Reels of 3 on sides  
Start: 1s dance in & cast, 2s cross up LH & 3s dance in, join NH facing down and cast up. All take hands where possible.  
End: 2s in 2nd places opp side, 1s & 3s end in middle, 1s NHJ facing down & 3s NHJ facing up
- 9-16** All set, circle left for 2 bars, Men turn Lady on right 2H once round & continue circle to places
- 17-24** 1s+2s dance RH across & end facing up, 1s cast 1 place & lead up **while** 2s lead up crossing & cast 1 place
- 25-32** 1s+2s dance Allemande

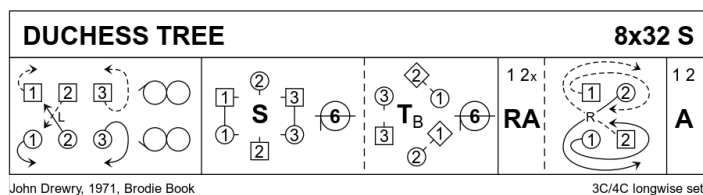

**7 POSTIE'S JIG J32 · 4/4L**

Roy Clowes: Thirty Popular Dances, Volume Two · Crib: MiniCribs · Diagram: Keith Rose's Diagrams

- 1-8** 1s & 4s set & cast in 1 place, 1s & 4s dance 1/2 Figs of 8 round new end couples
- 9-12** 1M+4M & 1L+4L cross (men making an arch) & turn corners with free hand to face up/down
- 13-16** 1s+4s dance down/up (couple dancing up make the arch) & turn corners
- 17-24** Repeat bars 9-16 from new positions
- 25-32** 1s+4s dance 1/2 R&L, turn partner RH

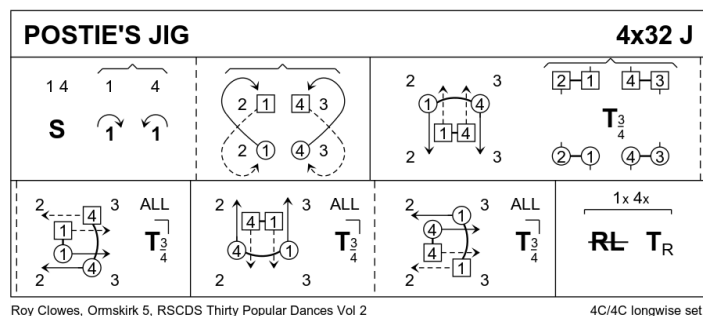

**8 THE IRISH ROVER R32 · 3/4L**

James B Cosh: Twenty Two SCD · Crib: MiniCribs · Diagram: Keith Rose's Diagrams

- 1-8** 1s dance down below 3s & cast up to 2nd place own sides, 1L dances RH across with 2s **while** 1M dances RH across with 3s
- 9-16** 1s dance 1/2 diagonal reel of 4 with 1st corners, 1/2 reel with 2nd corners & 1/2 turn LH in centre to face 1st corners
- 17-24** 1s dance reels of 3 across giving LSh to 1st corners ending in 2nd place own sides
- 25-32** 1s dance Diag R&L (1M crossing down & 1L crossing up to start)

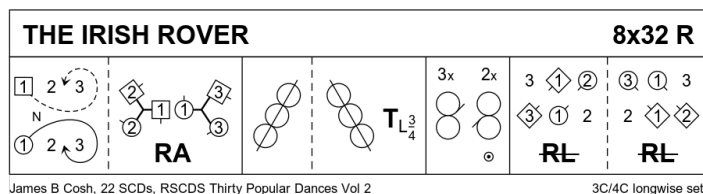

**PROGRAMME ITEM – Interval**

**9 THE FLIGHT OF THE FALCON J32 · 3/4L**

Barry Priddey: Anniversary Tensome · Crib: MiniCribbs · Diagram: Keith Rose's Diagrams

- 1-8 1s set, cast 1 place & turn LH to 1M facing his 1st corner with his partner behind him
- 9-16 1M followed by partner dance a full RSh diagonal Alternating Tandem reel of 3 with 1st corners & end facing Ladies 2nd corner
- 17-24 1M followed by partner dance a RSh Alternating Tandem reel of 3 with 2nd corners & 1s end facing own 1st corners
- 25-32 1s turn 1st corners RH, pass RSh, turn 2nd corner RH & pass RSh to 2nd place own sides (corners turn for 4 bars)

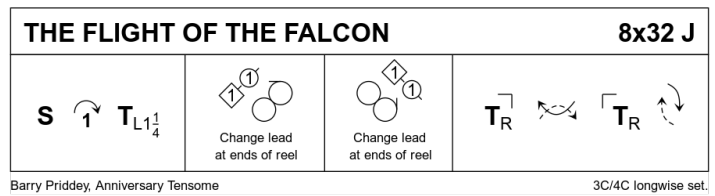

**10 CROSSING THE LINE R32 · 3/3L**

John Drewry: Bankhead Book Part 6 · Crib: MiniCribbs · Diagram: Keith Rose's Diagrams

Northern Hemisphere

- 1-8 1s cross down to dance reflection reels of 3 on opposite sides
- 9-16 1s (on opp sides) in prom hold dance a reel of 3 across with 2s giving RSh to 2nd Man
- 17-24 1s (on opp sides) dance down to bottom crossing & cast up to 2nd place, 1s turn RH (1s end facing out on own side)
- 25-32 1s cast right as 2s & 3s petronella turn into centre & 1s dance thru 2s/3s as they set, 1s cast to 2nd place as 2s & 3s petronella turn to opposite sides & all set. End 2 1 3 all on opposite sides

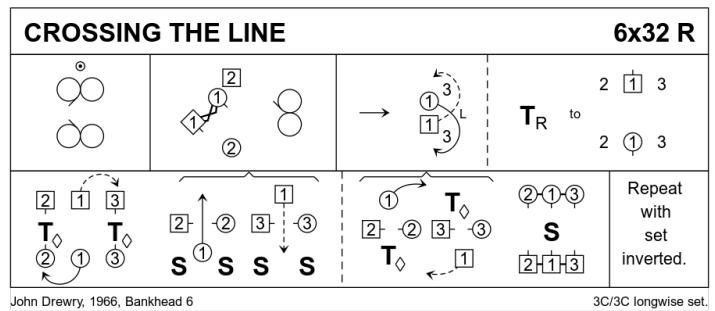

Southern Hemisphere

Repeat having crossed the Line into the Southern Hemisphere. New 1st couple are at the other end of the set reversing after each 32 bars

**11 FOXHILL COURT S32 · 3/4L**

John Drewry: The Canadian Book of Scottish Country Dances · Crib: MiniCribbs · Diagram: Keith Rose's Diagrams

- 1-8 1s+2s dance Espagnole:
  - 1-2 1s+2s cross (Ladies lead across RH passing between Men) with Ladies changing places RH
  - 3-4 1s+2s cross back (Men lead across RH between Ladies) with Men changing places RH
  - 5-8 2s turn RH as 1s turn LH to face 1st corners
- 9-20 Dance to Corners & Set: (12 bars)
  - Couple in middle change places with corners passing RSh, corners pass RSh in middle with a 1/4 turn to right to face next corner **while** supporting corners set (2 bars). Repeat 5 more times to end with corners in diagonally opposite place and 1s meet again in middle & pass RSh to face 3rd corner positions
- 21-24 1s turn 3rd corners 2H to face diagonally in (corners on 1s right) & set **while** 2nd corners set & cross RH
- 25-32 1s+3rd corners Adv+Ret & dance 3/4 RH across to end 2 1 3

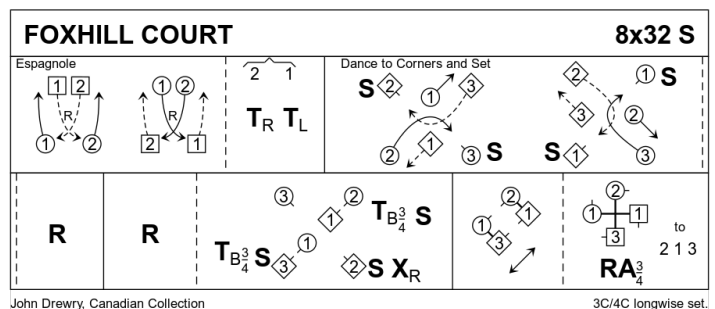

## 12 FATHER CONNELLY'S JIG J64 · 4/4L

John Drewry: *The Donside Book* · Crib: *MiniCribs* · Diagram: *Keith Rose's Diagrams*

- 1-8** 1s+2s Set & Rotate:  
Set, rotate singly & dance on 1 place clockwise, change places RH on sides & dance on 1 place to own sides. Order 2 1 3 4
- 9-16** 1s dance 1/2 diag R&L with 1st corners **while** 2nd corners set & change places diagonally RH, 1s dance 1/2 RSh reels of 3 on opposite sides (1M up, 1L down). (2)(1)(3) 4
- 17-24** 1s dance 1/2 diag R&L with 3rd corner (pstrn) **while** 2nd corners (pstrn) set & change places diagonally, 1s dance 1/2 RSh reels of 3 on own sides (1M down, 1L up). 2 1 3 4
- 25-32** 1s dance reels of 3 across Lady with 2s & Man with 3s (LSH to 1st corner)
- 33-40** 1s cross down between 3s, 1L casts up round 3M & 1M casts down round 4L, 1s change places LH in centre & cast to 3rd place own sides
- 41-56** 3s+1s+4s (bottom 3 couples) repeat bars 9-24. Order 2 3 1 4
- 57-64** All (or bottom 3 couples only) circle 8(6)H round & back. 1s step down to end 2 3 4 1

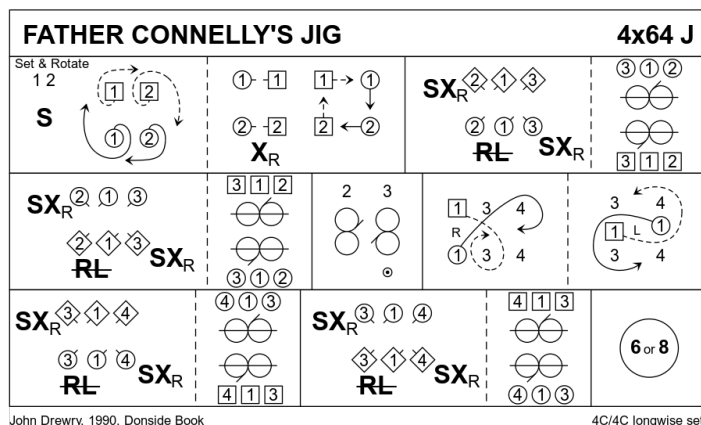

John Drewry, 1990, Donside Book

4C/4C longwise set.

## 13 THE FALLS OF ROGIE R32 · 3/4L

Jean Attwood: *Alexander Dances Book 1* · Crib: *MiniCribs* · Diagram: *Keith Rose's Diagrams*

- 1-8** 1s cross RH & cast 1 place, 1s cross RH & cast 1 place (Man up, Lady down)
- 9-16** 1s dance 1/2 reels of 3 across (1M with 2s & 1L with 3s), set in lines across & change places RH with opposite person
- 17-24** 2s+1s+3s chase clockwise 1/2 way, 1s dance in & turn 1.1/4 RH to face 1st corner positions as 2s & 3s continue to chase on to places (as bar 16)
- 25-32** 1s dance 1/2 reel of 4 with 1st corners, passing RSh dance 1/2 reel with 2nd corners & cross passing RSh to 2nd place own sides

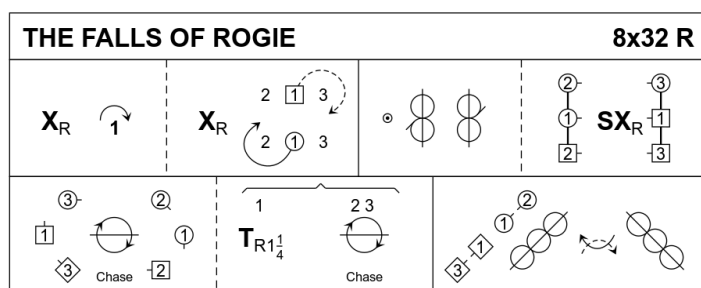

Jean Attwood, Alexander Dances Book 1

3C/4C longwise set.

## 14 THE FLOWER O' THE QUERN S32 · 4/4L

John Drewry: *The Canadian Book of Scottish Country Dances* · Crib: *MiniCribs* · Diagram: *Keith Rose's Diagrams*

3s & 4s start on opp sides

- 1-8** 1s+2s & 3s+4s circle 4H round to Left to end in middle, 1s facing 2s, 3s facing 4s. All set, 1s+4s turn inwards towards partner & cast in 1 pl down/up (2s dance up, 3s dance down one pl) & 1M+4L also 1L+4M change places LH on sides 2 (4) 1 (3)
- 9-12** 1s+4s lead out of ends, cross & cast. 1s+4s change places LH on sides.
- 13-16** 1s & 4s repeat 9-12, leading out other end, cross & cast & 1s+4s change places LH on side. 1s face down, 4s face up
- 17-24** All dance reels of 4 on sides & end facing same person as at start of reel. 2 4 1 3
- 25-32** 2s+4s also 1s+3s set facing on sides, 1s & 4s turn end couples (dancing between ends) & dance 1/2 Figs of 8 round end couples to end 2 4 (1) (3)

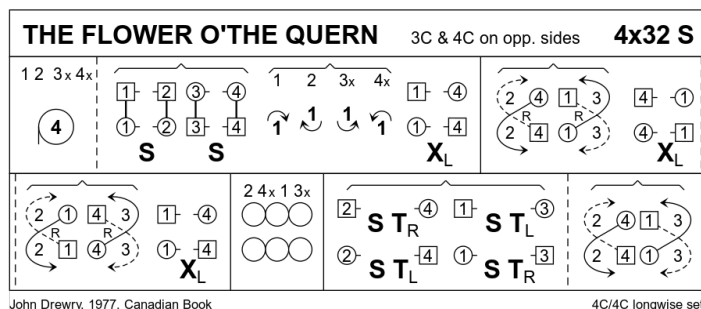

John Drewry, 1977, Canadian Book

4C/4C longwise set.

## 15 THE LAST OF THE LAIRDS J32 · 3/4L

Hugh A Thurston: *RSCDS XXII 5* · Crib: *MiniCribs* · Diagram: *Keith Rose's Diagrams*

- 1-8** 1s cross down (each couple cross down as they reach top place) to dance reflection reels of 3 on sides
- 9-16** 1s cross down (each couple cross down as they reach top place) to dance reflection reels of 3 on sides
- 17-24** 1s set & cross RH then cast 1 place, cross down between 3s & cast up to 2nd place on own sides
- 25-32** 1s lead up between 2s & cast down 1 place, 2s+1s+3s turn RH

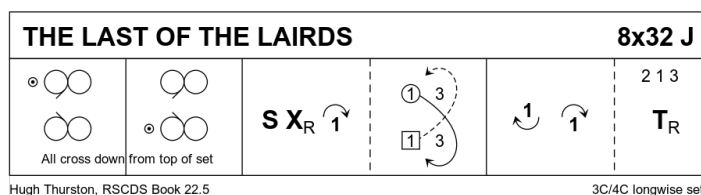

Hugh Thurston, RSCDS Book 22.5

3C/4C longwise set.

**16 MAIRI'S WEDDING R40 · 3/4L**

*James B Cosh: Twenty Two SCD · Crib: MiniCribbs · Diagram: Keith Rose's Diagrams*

- 1-8** 1s turn RH & cast to 2nd place (2s step up); 1s turn LH to face 1st corners
- 9-16** 1s dance 1/2 diagonal reel of 4 with 1st corners, 1s dance 1/2 diagonal reel with 2nd corners
- 17-24** 1s dance 1/2 diagonal reel with 3rd corner (pstns), 1/2 diagonal reel with 4th corner (pstns)
- 25-32** 1s dance reel of 3 across (Lady with 2s, Man with 3s - LSh to 1st corner)
- 33-40** 2s+1s+3s circle 6H round & back

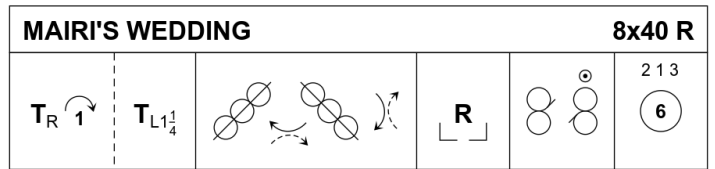

James Cosh, 1959, 22 SCDs, RSCDS Thirty Popular Dances Vol 2

3C/4C longwise set.