

# Atholl SCDC St Andrew's Night (almost)

## 1 ST ANDREW'S FAIR J32 · 3/4L

Roy Goldring: Five Scottish Country Dances 1982 · Crib: MiniCribbs · Diagram: Keith Rose's Diagrams

- 1-8 1s cross RH, cast 2 places, cross LH below 3s & cast up to 2nd place own sides
- 9-16 2s+1s+3s 1/2 turn RH retain hands & all set (M face down & L up) 2L leads Ladies across & down own side **while** 3M leads Men across & up
- 17-24 3s+1s+2s circle 6H round & back
- 25-32 3s+1s+2s 1/2 turn LH retain hands & all set (M face up & L down) 2L leads Ladies across & up own side **while** 3M leads Men across & down

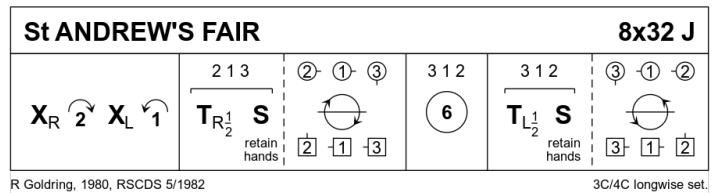

## 2 THE SALTIRE SOCIETY REEL R32 · 3/4L

Roy Goldring: The Leaflet Dances with Music · Crib: MiniCribbs · Diagram: Keith Rose's Diagrams

- 1-8 1s cross down & dance out between 2s+3s turning 3s by near hand to meet ptrn, dance up & turn 2s by nearest hand to 2nd place opp sides
- 9-16 1s cross down to 3rd pl & dance reel of 3 own side (2s dance out/down as 3s dance out/up b'tw'n 2s), 1s end (hold LH) facing 1st crnr
- 17-24 1s set to 1st crnr, turn inwards & set to 3rd corner as 3rd crnr set adv to dance RH across with 1s, 1s end turning to face 2nd crnr
- 25-32 1s repeat bars 17-24 with 2nd/4th corners but dancing LH across

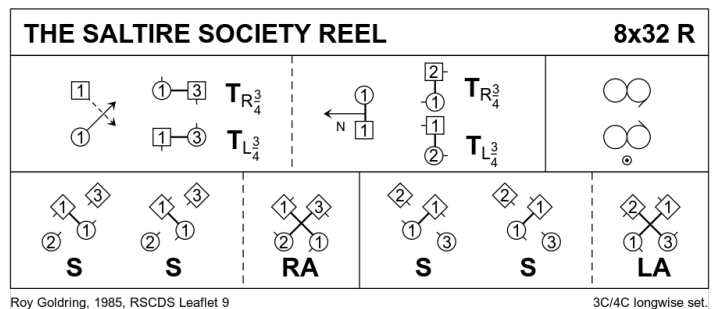

## 3 SAINT COLUMBA'S STRATHSPEY S32 · 5/5L

Vicky Sproule & Sadie L. Gillan: Saint Columba's Strathspey (Leaflet) · Crib: MiniCribbs · Diagram: Keith Rose's Diagrams

- 1-8 2s+4s dance RH across, 2s dance up **while** 4s dance down, 2s & 4s casting round ends on own sides to face 1st corners
- 9-16 2s+4s Pass+Turn with 1st corners, pass partner LSh & Pass+Turn with 2nd corners & into centre facing partner (L facing down M up)
- 17-24 2s+4s dance reel of 4 ending in original places on sides
- 25-32 2s & 4s set & cast down 1 place **while** 3s & 5s set & dance up 1 place, 1s & 2s turn RH & cast down 1 place. 3 1 5 2 4

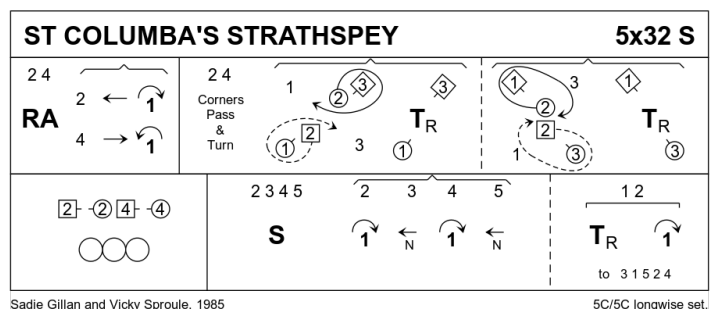

## 4 THE WAGGLE O' THE KILT J40 · 3/4L

James B Cosh: Twenty Two SCD · Crib: MiniCribbs · Diagram: Keith Rose's Diagrams

- 1-8 1s cast 1 place & lead down between 3s, cast up to 2nd place & turn LH to end BtoB facing own sides
- 9-16 1s dance RH across (1M with 2M+3M & 1L with 2L+3L), 1s passing RSh dance RH across with other side (1s end facing 1st corners)
- 17-24 1s dance 1/2 diagonal reel of 4 with 1st corners & pass LSh, 1/2 reel of 4 with 2nd corners & end facing 3rd corner (pstn)
- 25-32 1s+3rd corners 1/2 turn RH & corners turn LH 1.1/2 times in centre to face opp corner, 1s+corners 1/2 turn RH & 1s turn LH to face 4th corners
- 33-40 1s+4th corners 1/2 turn RH & corners turn LH 1.1/2 times in centre to face opp corner, 1s+corners 1/2 turn RH & 1s turn LH to 2nd place. 2 1 3

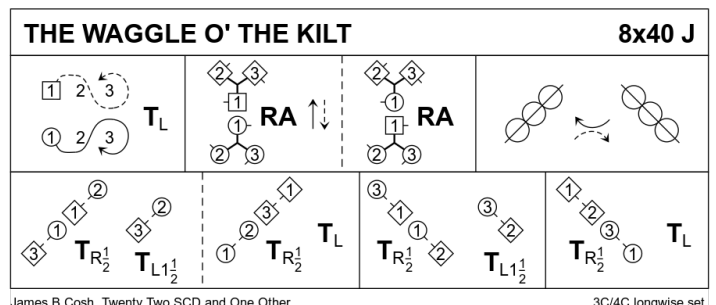

**5 ST ANDREW'S OF BRAMPTON R32 · 4/4L**

*Ann Campbell: RSCDS XXXVII 5 · Crib: MiniCribbs · Diagram: Keith Rose's Diagrams*

- 1-8** 1s & 4s cross RH, cast in 1 place & dance RH across once round in the centre retaining hold of RH
- 9-16** 1s+4s pick up corners on LH & all dance round 2 places (St Andrews cross formation), set to corner & change places LH
- 17-24** 2s+3s form RH star in centre with corners on LH & dance round 2 places, set & change pl with corners (2s & 3s pass between 1s & 4s)
- 25-32** 1s & 4s with nearer hands joined dance out of ends & cast back to centre, 1s+4s dance 1/2 R&L ending in psts 2 4 1 3

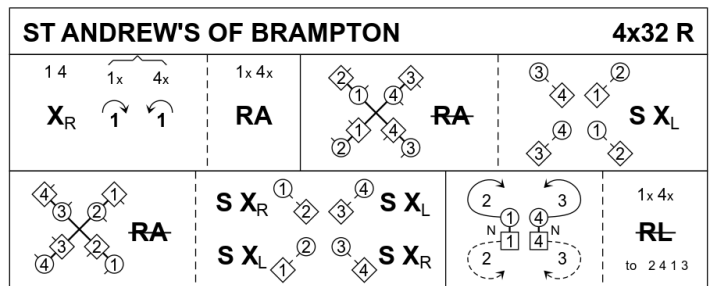

Ann Campbell, RSCDS Book 37.5

4C/4C longwise set.

**6 ATHENS OF THE NORTH S32 · 3/4L**

*Atsuko Clement: 90 - Twelve anniversary dances celebrating ninety years of RSCDS Edinburgh Branch 5 · Crib: MiniCribbs · Diagram: Keith Rose's Diagrams*

- 1-8** 2s followed by 1s dance down (2 steps), turn partners 2H. 1s followed by 2s dance up, 1s+2s 1/2 turn (M Left hand, L Right hand) 2 1 3
- 9-16** 2s+1s+3s dance Diag R&L. 1s finish facing out in 2nd place (3) 1 (2)
- 17-24** 3s+1s+2s dance RSh reels of 3 on sides (1M+3L & 1L+2M pass RSh to start)
- 25-32** 3s+1s+2s dance clockwise 1/2 way round & turn partners 2H (1s turn 1.1/2 times) Order: 2 1 3

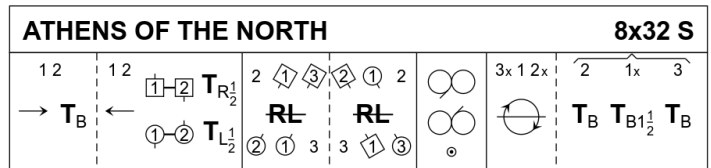

Atsuko Clement, Edinburgh 90

3C/4C longwise set.

**7 CITY OF STIRLING REEL R32 · 3/4L**

*Roy Goldring: Bannockburn 700 · Crib: MiniCribbs · Diagram: Keith Rose's Diagrams*

- 1-8** 1s+2s+3s dance Snowball Grand Chain (1s+2s change places on sides to start). (3)(1)(2)
- 9-16** 1s cross (pass RSh) & 1/2 turn RH person in 3rd corner, 1s followed by corners change places (diag) passing LSh & 1s cast to 2nd place (opp sides) as corners end in original places
- 17-24** 1s cross (pass LSh) & 1/2 turn LH person in 4th corner, 1s followed by corners change places (diag) passing RSh & 1s cast to 2nd place (opp sides) as corners end in original places. 2(1)3
- 25-32** All turn RH (4 bars) & 1s dance 1/2 Figs of 8 (Lady up & Man down)

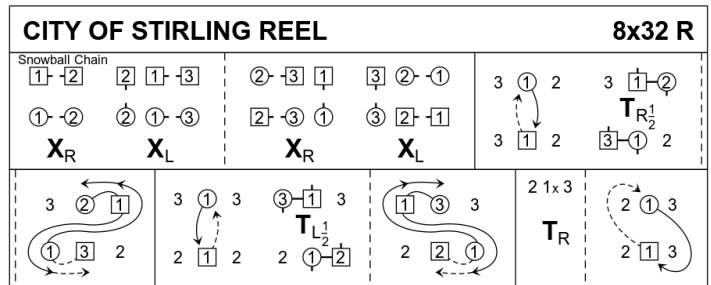

Roy Goldring, 2005, Auld Friends Meet

3C/4C longwise set.

**8 GOOD HEARTED GLASGOW J32 · 3/4L**

*Peter Knapman: A Guide to Scottish Country Dancing (ex-Collins) · Crib: MiniCribbs · Diagram: Keith Rose's Diagrams*

- 1-8** 1s turn RH & cast to 2nd place, turn partner LH 1.1/4 times
- 9-16** 1s dance RH across (Lady with 2s at top & Man with 3s); 1s pass RSh & dance LH across with other couple
- 17-24** 1s lead down the middle & back to 2nd place own side
- 25-32** 2s+1s+3s circle 6H round & back

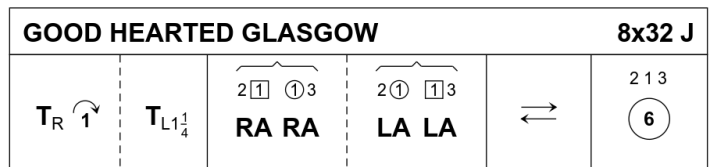

Peter Knapman, 1988, Collins Pocket Reference

3C/4C longwise set.

**INTERVAL**

**9 A CAPITAL JIG** J32 · 3/4L

Tine E MacKay: Magazine Dances 2005-2009 · Crib: MiniCribbs · Diagram: Keith Rose's Diagrams

- 1-8** 1s+2s Set & Rotate & end 1s facing up, 2s down:  
Set, rotate singly & dance on 1 place clockwise,  
change places RH on sides & dance on 1 place to  
own sides (1s in 2nd place facing up)
- 9-16** 1s dance reels of 3 on own sides (RSh to 2s)
- 17-24** 1s set & turn 3/4 RH to face own sides, 1s dance LH  
across (1L with 2s, 1M with 3s) to end 2nd place  
opposite sides
- 25-32** 1s set & turn 3/4 RH to face opposite sides, 1s dance  
LH across (1M with 2s, 1L with 3s) ending 2nd place  
own sides

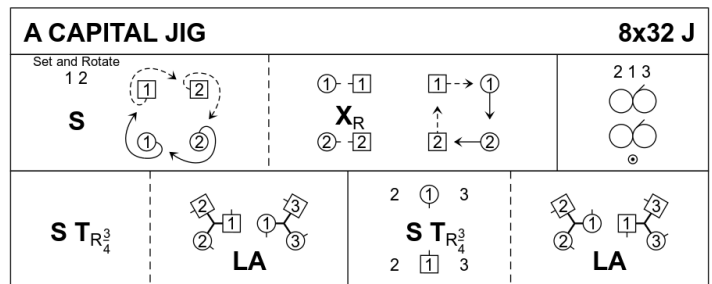

Tine Mackay, RSCDS 5/2009

3C/4C longwise set.

**10 FISHERMAN'S REEL** R32 · 5S

Petyt, Sue / Gamon, Jane: Dunblane Holiday · Crib: MiniCribbs · Diagram: Keith Rose's Diagrams

5 couple square set, 5s in centre facing, 5M back to 4s, 5L back to 2s

- 1-8** 1s+2s+3s+4s circle 8H round & back **while** 5s turn  
RH once & LH 1.1/2 times to end 5M facing 2s & 5L  
facing 4s
- 9-16** 5M+2s also 5L+4s dance RH across, 5s pass LSh &  
dance LH across with next couple anticlockwise (M  
with 1s & L with 3s)
- 17-24** 5M dances reel of 3 with 1s+2s (in prom hold) giving  
RSh to 2s **while** 5L reels with 3s+4s giving RSh to 4s
- 25-32** All take ptrns in prom hold, 5s change pl with 1s RSh,  
1s pass 4s RSh, 4s pass 3s RSh, 3s pass 2s RSh &  
2s end in centre facing each other

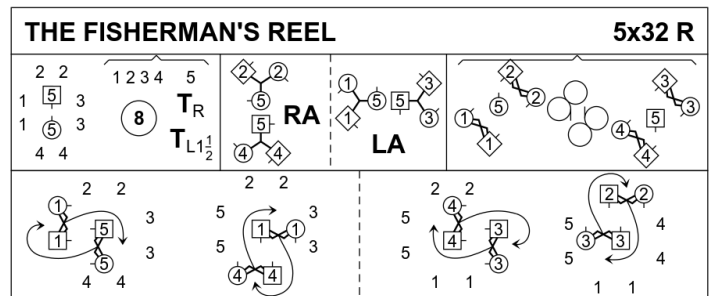

Sue Petyt, 1994, Dunblane Holiday

5C/5C square set.

**11 THE DUNDEE WHALER** S32 · 4/4L

Roy Clowes: Ormskirk Scottish Dances - Memorial Edition · Crib: MiniCribbs · Diagram: Keith Rose's Diagrams

- 1-8** 2s & 4s dance 1/2 Petronella figure to opposite sides  
(petronella turn & set, twice)
- 9-16** 1s+2s & 3s+4s dance Ladies' Chain
- 17-24** 1s & 3s dance 1/2 Petronella figure to opposite sides  
(petronella turn & set, twice)
- 25-32** 1s "zig-zag" to 4th place, 1L starting changing places  
diagonally LH with 2M:  
1L+2M change places LH, 1M+2L also 1L+3L change  
places RH, 1M+3M also 1L+4M change places LH &  
1M+4L change RH

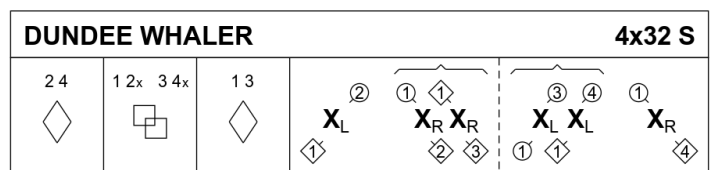

Roy Clowes, Ormskirk

4C/4C longwise set.

**12 BIRLS ALLOWED** J32 · 3/4L

Alex Taylor: Bannockburn 700 · Crib: MiniCribbs · Diagram: Keith Rose's Diagrams

- 1-8** 1s cross RH & cast 2 places (3s face down), 1s with  
3s+2s dance 1/2 reflection reel of 3 (1s dancing in/up,  
3s down/out, 2s in/down to start) (1) 3 2
- 9-16** 1s cross down to dance full reels of 3 on own sides. 1  
3 2
- 17-24** 3s+2s (bottom 2 couples) Set & Rotate:  
Set, rotate singly & dance on 1 place clockwise,  
change places RH on sides & dance on 1 place to  
own sides (3s in 2nd pl). 1 2 3
- 25-32** 1s+2s dance 1/2 R&L, 2s+1s turn partner 1.1/2 times RH. 2 1 3

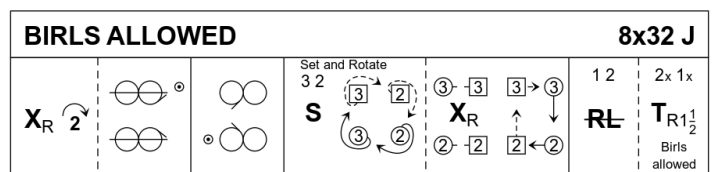

Alex Taylor, 2010

3C/4C longwise set.

### 13 THE CLANSMAN R32 · 2/4L

Derek Haynes: RSCDS XXXII 8 · Crib: MiniCrib · Diagram: Keith Rose's Diagrams

- 1-8 1s cross RH & cast down 1 place, 2s+1s dance 1/2 RH across & set
- 9-16 1s+2s dance R&L, ending with Men turning Ladies into centre to form a line across
- 17-24 1s+2s dance the Targe :  
**17-18** 1st & 2nd Ladies 3/4 turn RH **while** Men dance 1/4 way round anticlockwise  
**19-20** 1st Man with 2nd Lady & 1st Lady with 2nd Man full turn LH  
**21-22** 1st & 2nd Ladies 3/4 turn RH **while** Men dance 1/4 way round anticlockwise  
**23-24** 1st Man with 2nd Lady & 1st Lady with 2nd Man turn 3/4 LH to end on sides 1s facing up & 2s facing down
- 25-32 2s+1s set facing on sides, turn to face partners & set, 1s lead up crossing RH & cast to 2nd place on own sides

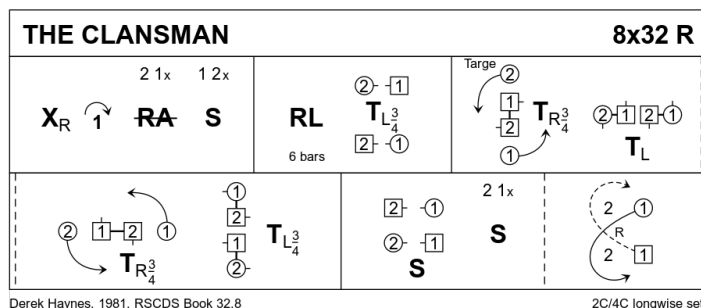

### 14 THE BELLE OF BON ACCORD S32 · 4/4L

John Drewry: Deeside Book Part 2 · Crib: MiniCrib · Diagram: Keith Rose's Diagrams

- 1-8 1L & 3L cross down 1 pl & cast up on opp side into centre as 1M & 3M dance across & cast down into centre, 1s+2s & 3s+4s dance RH across
- 9-16 1s & 3s dance reel of 4 up & down centre of dance
- 17-24 1s & 3s 3/4 turn RH to face up **while** 2s & 4s dance up on sides & turn in to face down & all set, all circle 4H round to left & end on sides
- 25-32 1s & 3s lead up between 2s/4s crossing over & cast down 1 place, 1s & 3s turn 2H & 1s dance down to 4th place as 3s cast up on own sides to 2nd pl

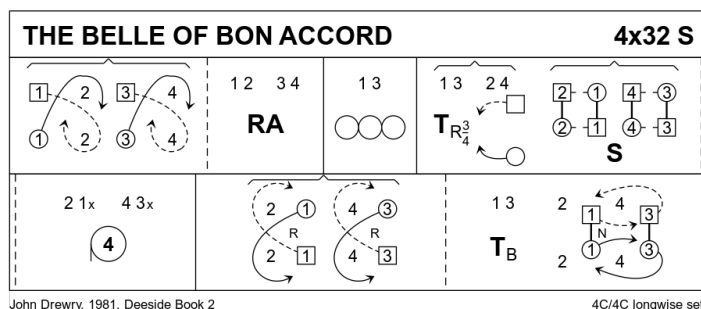

### 15 THE LAST OF THE LAIRDS J32 · 3/4L

Hugh A Thurston: RSCDS XXII 5 · Crib: MiniCrib · Diagram: Keith Rose's Diagrams

- 1-8 1s cross down (each couple cross down as they reach top place) to dance reflection reels of 3 on sides
- 9-16 1s cross down (each couple cross down as they reach top place) to dance reflection reels of 3 on sides
- 17-24 1s set & cross RH then cast 1 place, cross down between 3s & cast up to 2nd place on own sides
- 25-32 1s lead up between 2s & cast down 1 place, 2s+1s+3s turn RH

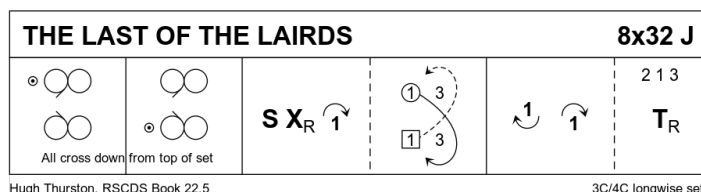

### 16 BRATACH BANA R32 · 3/4L

John Drewry: Thirty Popular Dances, Volume Two · Crib: MiniCrib · Diagram: Keith Rose's Diagrams

- 1-8 1s turn RH & cast 1 place, 1s dance LSh round 1st corners to 2nd place opposite side facing 2nd corners
- 9-16 1s dance 1/2 RSh reel of 3 on the sides & dance 1/2 LSh reel of 3 across (1M with 3s at top, 1L with the 2s, LSh to 3rd corner position)
- 17-24 1s turn 3/4 LH, turn 3rd crnr RH (1st crnr person) & pass RSh to turn 4th crnr RH ending in 2nd pl own side in prom hold with 4th crnr
- 25-32 1s+4th crnr promenade diagonally across (pass RSh) to diag opp crnr & 1/2 turn to end 1s in 2nd pl opp side, 1s dance 1/2 Diag R&L (M up, L dn) to end in 2nd place. 2 1 3

