

# Atholl SCDC Week 6 Graham & Sylvia's Programme 19/10/21

Website: [www.athollscdc.co.uk/](http://www.athollscdc.co.uk/)

## 1 MISS HADDEN'S REEL J32 · 3/4L

RSCDS: RSCDS XXIII 5 · Crib: E-cribs · Diagram: Keith Rose's Diagrams

- 1- 1c+2c+3c Circle6 and back
- 9- 1c set | cast off (2c up) ; 2c+1c+3c turn RH into
- 17- 2c+1c+3c Allemande (3,1,2)
- 25- All A&R ; 3c followed by 1c cast off and 2c dance up to (2,1,3) (second time: 3c dance through 4pl to 3pl and 1c dance to 4pl)

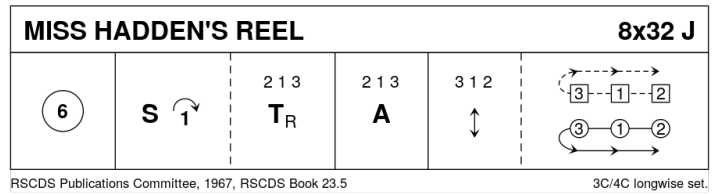

## 2 PORTNACRAIG R32 · 3/4L

Linda C Gaul: RSCDS XXXVI 1 · Crib: E-cribs · Diagram: Keith Rose's Diagrams

- 1- 1c set (no advance), turn BH 1/2 into the middle NHJ facing 2c diagonally (drop hands) ; 1c set to 2c and face out | turn 2c EH 1/2 (2,1x,3)
- 9- All A&R ; 1/2 circle6 L (3x,1,2x)
- 17- 1c pass Lsh into 1/2 Rsh Reel4 with 1cnrs, pass Lsh into ; 1/2 Rsh Reel4 with 2cnrs (to 2,1x,3)
- 25- 1c 1/2 Fig8 round 3c ; All turn RH (2,1,3)

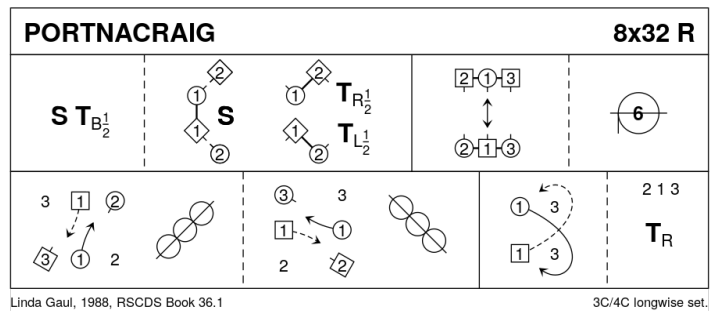

## 3 GANG THE SAME GATE S32 · 3/4L

Milton Levy: RSCDS XXXVI 4 · Crib: E-cribs · Diagram: Keith Rose's Diagrams

- 1- 1c cross RH | cast off 2 (2c+3c up) ; 1c cross RH and cast up (3c down) to (2,1,3)
- 9- 1c set passing Lsh | turn 1cnrs BH ; 1/2 Reel4 with 2cnrs, at end 1c curve R to between end cpl (M above facing W below)
- 17- 1c set passing Lsh, turn 4c (2c nr persons) BH ; 1/2 Reel4 with 1cnrs, at end curve R to end as (3x,1x,2x)
- 25- All S&Link3 ; repeat (2,1,3)

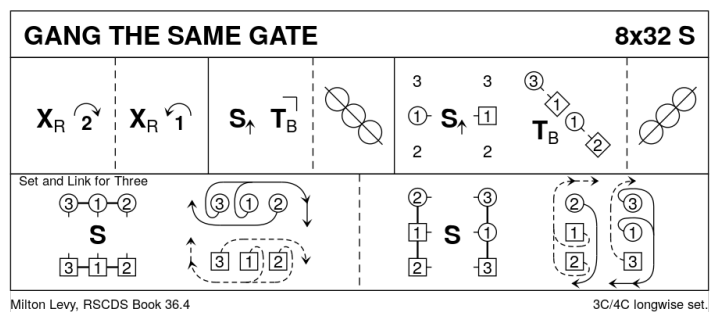

## 4 FAREWELL TO CRUMLIN J32 · 4/4L

Wilson Brown: RSCDS XXXII 4 · Crib: E-cribs · Diagram: Keith Rose's Diagrams

- 1- 1c+2c set | 1/2 RHA ; 2c+1c+3c 1/2 Rsh Reels3 (1c start up) (3,1x,2x,4)
- 9- 1c+2c LHA while{4} 3c+4c chase clw halfway around (4M & 3W cast, P follows) ; 4c+1c and 2c+3c turn RH in sideline (4x,1x,2x,3x)
- 17- Rsh Reels4 in sideline
- 25- All set and 4c+2c cast off 1 place (1c+3c up) ; 1/2 circle8 to L (to 2,3,4,1).

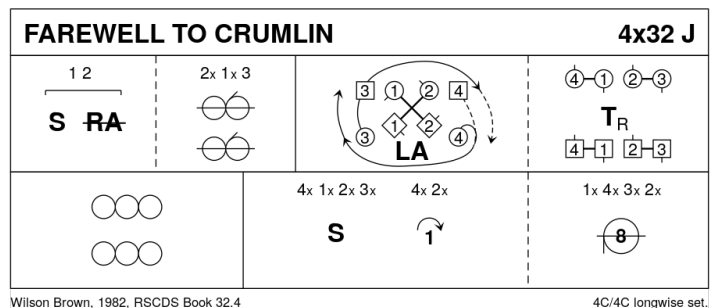

**5 THE DANCERS' WEDDING R32 · 3/4L**

*Jimmie Hill: RSCDS XLI 3 · Crib: E-cribs · Diagram: Keith Rose's Diagrams*

- 1- 1c turn RH ½ | set to P with RHJ (2c up) ; 1c lead down, cross below 3c and cast up to (2,1,3)
- 9- All A&R ; ½ Reels3 across (Lsh to 1cnr) (2x,1x,3x)
- 17- All A&R ; ½ Reels3 across (Lsh to 3cnr pos), 1c finish LHJ with P and RHJ with 4cnr
- 25- the Spoke: BiL{1}, advance LHJ cclw to next cnr {1} | repeat 3 times, on [31-32] 1c petronella turn to (2,1,3)

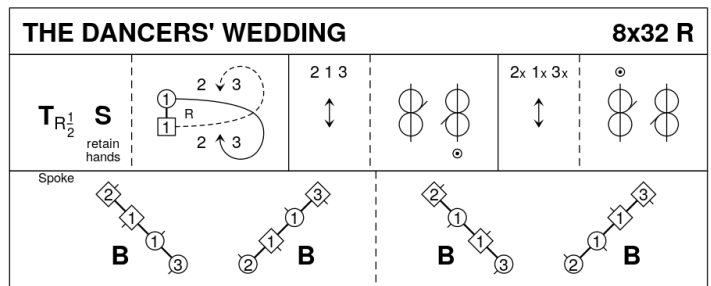

Jimmie Hill, 1998, RSCDS Book 41.3

3C/4C longwise set.

**6 THE GENTLEMAN S32 · 3/4L**

*Roz Scott Huxley: RSCDS XXXV 5 · Crib: E-cribs · Diagram: Keith Rose's Diagrams*

- 1- 2c step up as 1c turn BH to face P between them in line4 across | 1c+2c set, 1c advancing and passing on the second step ; ½Reel4, at end 1c pass LH to face down NHJ
- 9- 1c dance down to face P between 3c, repeat set and ½Reel4 with 3c, finish between 3c on own side LHJ
- 17- 1c lead to top, cross and cast to 2plx ; ½Reels3 across, Rsh to 4cnr (W up, M dn) (to 2,1,3)
- 25- 2c+1c Poussette.

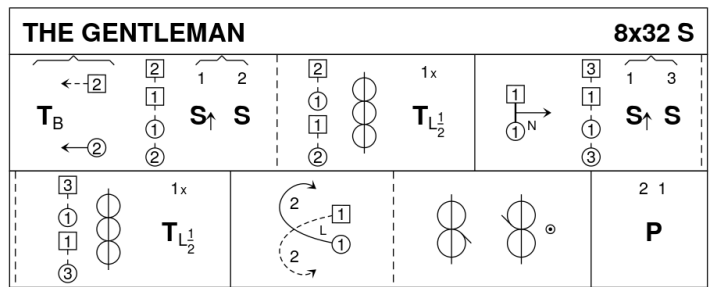

Roz Scott Huxley, 1986, RSCDS Book 35.5, RSCDS Thirty Popular Dances Vol 2

3C/4C longwise set.

**7 LINKS WITH ST PETERSBURG J32 · 3/4L**

*Malcolm Brown: RSCDS XLVI 10 · Crib: E-cribs · Diagram: Keith Rose's Diagrams*

- 1- 1c+2c S&Link, finish 2c facing 1c NHJ ; S&Link to (2x,1x,3)
- 9- 1c, 2c following, dance down {3}, change sides with NHJ, W passing above M and under his arm, 2c+1c dance up to (2,1,3), 2c facing out
- 17- 2c turn 1c EH on sides ; 1c turn 3c EH, 1c finish BtoB facing 1cnr
- 25- SetH&G , petronella to (2,1,3)

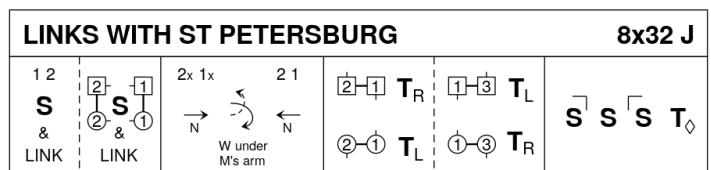

Malcolm Brown, 2009, RSCDS Book 46.10

3C/4C longwise set.

**8 FLOWERS OF EDINBURGH R32 · 3/4L**

*RSCDS I 6 · Crib: E-cribs · Diagram: Keith Rose's Diagrams*

- 1- 1W followed by 1M casts off 2, 1W crosses below 3c and casts up M side while 1M dances up the middle, both to P's place {6} | 1c set
- 9- 1c repeat with 1M casting, finishing in original places
- 17- 1c lead down the middle and up
- 25- 1c+2c Poussette

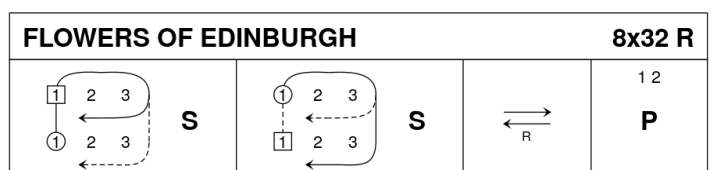

Hughes, 1867, RSCDS Book 1.6

3C/4C longwise set.

**9 THE MACHINE WITHOUT HORSES J32 · 3/4L**

*David Rutherford: RSCDS XII 12 · Crib: E-cribs · Diagram: Keith Rose's Diagrams*

- 1- 1c set | cast off (2c up) ; 1c+3c RHA
- 9- 1c set | cast up (2c down) ; 1c+2c LHA
- 17- 1c followed by 2c dance between 3c, cast up round them, dance up, 1c cast off to 2pl, while 2c dance into 1pl (no loops)
- 25- 2c+1c R&L

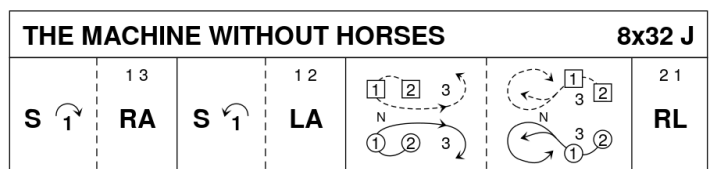

Rutherford, 1772, RSCDS Book 12.12

3C/4C longwise set.

## 10 INVERNEILL HOUSE R32 · 3/4L

John Drewry: RSCDS XXXV 2 · Crib: E-cribs · Diagram: Keith Rose's Diagrams

- 1-- 1c+2c ½ DblFig8 (to start, 1c cross down and 2c dance up, 2c finish facing out) ; 1c dance down NHJ between 3c and cast up to 2plx **while(4)** 2c cast up and stand (2x,1x,3)
- 9-- 1c+3c ½ DblFig8 (1c cross down and 3c dance up) ; 1c dance up NHJ between 2c and cast off to 2pl own side (2x,1,3x)
- 17-- 1c Petronella {8} (to 2x,1x,3x)
- 25-- 2c+3c Petronella {8} **while** 1c casts Rsh back | cross (M / W between 3c /2c) ; cast to 2pl | set with 2c+3c (2,1,3)

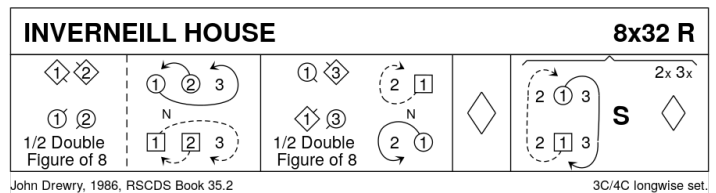

## 11 YSOBEL STEWART OF FISH HOEK S32 · 3/4L

Mervyn C Short: RSCDS LII 8 · Crib: E-cribs · Diagram: Keith Rose's Diagrams

- 1-- 1c+2c Tourbillon (2,1,3)
- 9-- 1c+1cnrs set, 1c advancing BtoB to 1cnrs | turn 1cnrs BH into lines3 across ; repeat [9-12] with 2cnrs (2,1x,3)
- 17-- ½ Reel4 on 1diag, 1c passing P Lsh, into lines3 across ; ½ Reel4 on 2diag, 1c passing P Lsh (3x,1,2x)
- 25-- 1W+3c & 1M+2c Circle3 L {3}, open (1c leading) into ½ Circle6 L {3} | 1c cross RH (2,1,3)

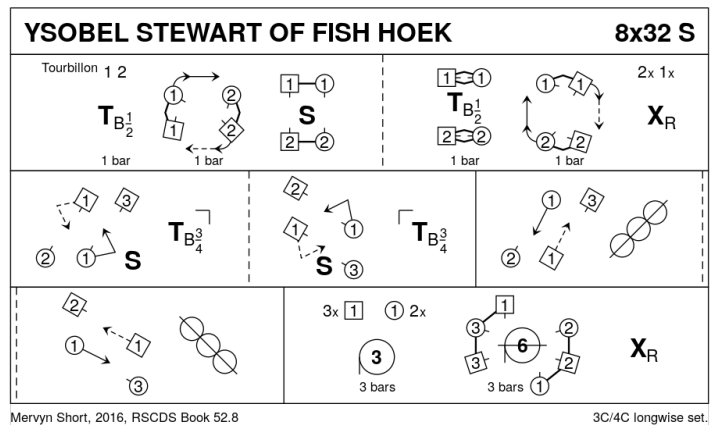

## 12 THE CHEQUERED COURT J32 · 3/4L

Duncan Brown: RSCDS XLII 3 · Crib: E-cribs · Diagram: Keith Rose's Diagrams

- 1-- 1c cross RH | cast off (2c up) ; ½ Fig8 across to the R (1M up, 1W down) to face 1cnr
- 9-- 1c+1cnrs pass and turn, at end 1c swivels R to be BtoB facing 4cnr ; 1c+4cnrs pass and turn, 1c swivels R to finish BtoB facing own side for
- 17-- DTr, 1c finish between end couple facing own side
- 25-- Reels3{6} across (Rsh to 4cnr) | 1c cross RH (2,1,3)

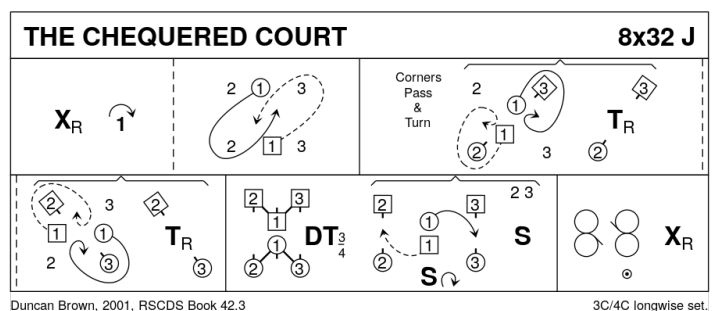

## 13 THE CLANSMAN R32 · 2/4L

Derek Haynes: RSCDS XXXII 8 · Crib: E-cribs · Diagram: Keith Rose's Diagrams

- 1-- 1c cross RH | cast off (2c up) ; 2c+1c ½ RHA | set to P (1,2x)
- 9-- 1c+2c R&L, finish with ¾ LH turn into line across, the W in the centre:
- 17-- The Targe (1W+2W turn ¾ RH **while(2)** 1M+2M chase ¼ round cclw | 1M+2W & 1W+2M Turn LH ; repeat) finishing on sides (2,1x)
- 25-- 2c facing 1c set | all set to P ; 1c lead up, cross and cast to 2pl (2,1)

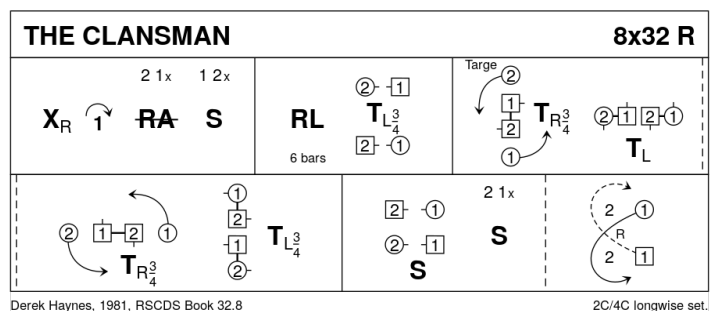

**14 MACDONALD OF KEPPOCH M128 · 4S**

Chris Ronald: RSCDS XLIX 11 · Crib: E-cribs · Diagram: Keith Rose's Diagrams

- 1-- 1c+3c ¾ R&L to BtoB facing sides | all set
- 9-- Parallel Reels4 across, 1c+3c finish half way the last left pass, in a line up and down the set
- 17-- 1c+3c Lsh Reel4, 1W+3W pass Rsh in middle to start, to finish in original places
- 25-- All set to P | all turn P RH 1¼ | all in promhold chase cclw ¼ (2,3,4,1)

The first two turns are in Strathspey time, the second two are in Reel time.

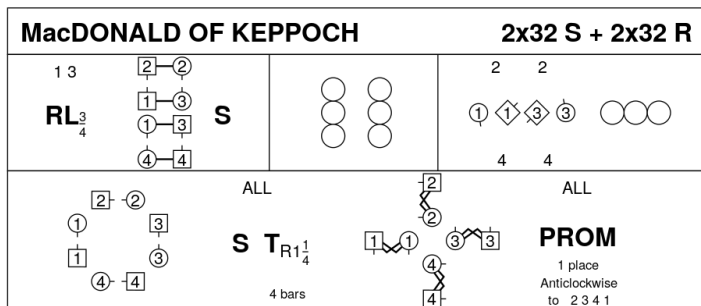

Chris Ronald, 2013, RSCDS Book 49.11

4C/4C square set.

**15 MAJOR IAN STEWART J32 · 3/4L**

John Drewry: RSCDS XXXV 4 · Crib: E-cribs · Diagram: Keith Rose's Diagrams

- 1-- 1c+2c turn RH ½ into | ½ RHA into ; 2c+1c turn RH, 2c finish facing out (2,1,3)
- 9-- Opposing Reels3 on own sides (1c inwards, Rsh to 4cnr) 1c finish facing 1cnr, 2c+3c finish with loops
- 17-- SetH&G to (2,1,3)
- 25-- Circle6 L {3}, cross R foot over L and chase back cclw to (2,1,3)

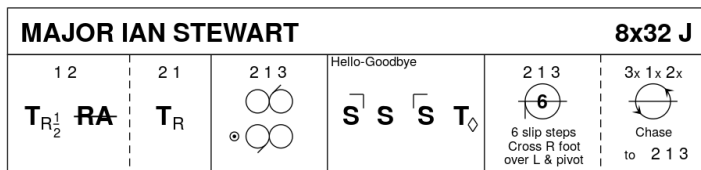

John Drewry, 1986, RSCDS Book 35.4

3C/4C longwise set.

**16 THE REEL OF THE ROYAL SCOTS R32 · 3/4L**

Roy Goldring: The Leaflet Dances with Music · Crib: E-cribs · Diagram: Keith Rose's Diagrams

- 1-- 1W+2W (1M+2M) turn LH (RH) ½, finishing 1c BtoB in 2pl | All set as in DTr ; 1W+3W (1M+3M) turn RH (LH) ½ | 2c+3c+1c set as in DTr
- 9-- 1c followed by 3c dance up between 2c, cast off ; dance NHJ down through 3pl, cast up to face 1cnrs, 3c looping into 3pl
- 17-- 1c turn 1cnrs RH, pass Rsh (cnrs dance for {4}) ; turn 2cnrs RH (same), and cross Rsh to (2,1,3)
- 25-- All circle6 and back

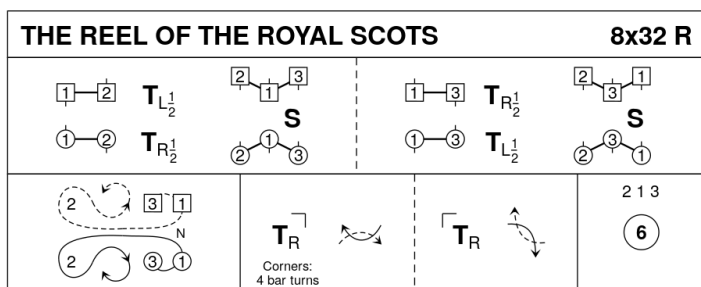

Roy Goldring, 1983, RSCDS Leaflet 7

3C/4C longwise set.